

ThorburnFlex



Clean Power Generation



Petrochemical Processing



Hydro/Pyro Metallurgical Processing

FLEXI-DUCT™ EXPANSION JOINTS

Engineered Solutions For Flue Gas Duct Motion



www.thorburnflex.com

Engineered Solutions For Flue Gas Ducting Applications



Thorburn's global headquarters in Montreal Quebec Canada

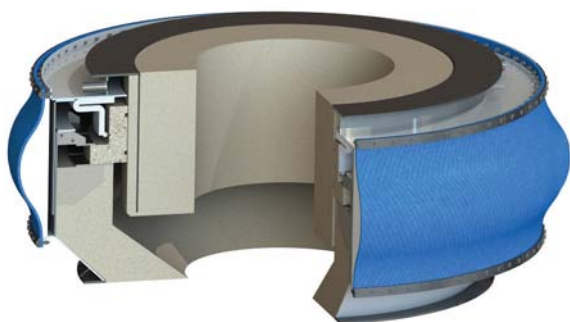

Thorburn's refractory lined "Zero-Gap" Flexi-Duct™ expansion joint

Table Of Contents

Thorburn's Flexi-Duct™ Catalog will introduce to the reader our flue duct expansion joint materials and designs for fossil fuel power plants, gas powered combined cycle power plants, material processing and other related industries.

Manufacturing Capabilities	3
Site Services	4
Installation Commissioning Services & Testing	5
Flexi-Duct™ Introduction, Markets & Applications	6-7
Flexi-Duct™ (FDC) GSMs	8-13
Flexi-Duct™ Elastomeric Flue & Air Duct EJs	14-15
Flexi-Duct™ Frames & Clamps	16
Flexi-Duct™ Flow Liners & Backing Bars	17
Flexi-Duct™ Cavity Pillow	18
Flexi-Duct™ Insulation Retaining Bag	19
Flexi-Duct™ Gaskets, PTFE & Treated Textiles	20
Flexi-Duct™ Pantograph & Integral Drainage Systems	21
How to Order Flexi-Duct™ Expansion Joints	22-23
Flexi-Duct™ CT & HRSG EJ Applications	24-27
Flexi-Duct™ Pulverized Coal EJ Applications	28-29
Flexi-Duct™ CFB EJ Applications	30-31
Flexi-Duct™ Quick-Clamping System	32
Flexi-Duct™ Aluminum EJ Applications	33
Flexi-Duct™ Bootflex PTFE Expansion Joints	34
Flexi-Duct™ Bootflex TCT Rubber Expansion Joints	35
Accessories	36-39
Thermal Expansion Chart	40
Conversion Factors (SI Units)	41-43
Glossary of Terms	44-46
Flexi-Duct™ Expansion Joint Data Specification Sheet	47

Edition 04/16/2025

Thorburn has been solving the most challenging flue duct motion problems for over 50 years worldwide

Operating under a global presence and employing the most talented and dedicated specialists in the world, Thorburn provides our EPC and OEM clients with the latest technologies and solutions in flue duct expansion joints. Thorburn has gained international acclaim as the worlds most innovative, solutions driven, flue duct expansion joint manufacturer with manufacturing capabilities in Canada, Mexico, South Africa, Nigeria, Egypt, Poland, Australia, Malaysia, Indonesia and China, and has representation and engineering presence in USA, Argentina, Chile, Iran, Romania, Lithuania, Belarus, Russia, Japan and South Korea.

Thorburn's Major Strengths in Flue Duct Expansion Joints:

- Customer driven, single point contact for ease of communication
- Manufacturing capabilities close to job sites to decrease costs and increase support
- Experienced engineers providing reliability through best industry practices and standards
- Advanced design software such as FEA to address the challenges of thermal and mechanical stress

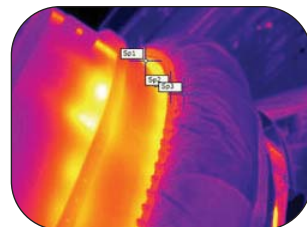

Thorburn's engineers use IR cameras and FEA to optimize Flexi-Duct™ metallic frame design for challenging high temperature applications

Thorburn's Expansion Joint Services

- Failure mode investigation, analysis, recommendations & countermeasures
- Expansion joint refurbishment supervision
- Expansion joint installation training
- IR plant surveys of all fabric expansion joints while turbine is online and hot
- Process data section by section showing the condition of all expansion joints
- Priority list and changeout schedule with details of remaining lifespan of expansion joints
- GSM splice training & equipment supply
- Emergency installation & repairs
- Final inspection of expansion joints



Thorburn's technician providing on-site training at a CFB power plant in Jacksonville Florida USA

Quality Standards & Compliances:

- PED 2014/68/EU
- CE Certification Mark
- ISO 3834-2 & ISO 9001 : 2015 Edition
- ASME Sec VIII, Div 1, "U" Stamp
- Russian GOST R & EAC Certifications
- Fluid Sealing Association (FSA) & European Sealing Association (ESA)
- Welding & Welding Procedures Qualified to ASME Section IX for Sub ARC, ARC, Pulse ARC, TIG, MIG Core Wire & Resistance
- NDE (Radiography, Dye Penetrant, Magnetic Particles) Qualified to ASME Section V
- NDT Technicians Qualified to SNT-TC-1A, Level II

Manufacturing Capabilities



Thorburn's technician in South Africa installing a cavity pillow on a Flexi-Duct™ inlet HRSG expansion joint

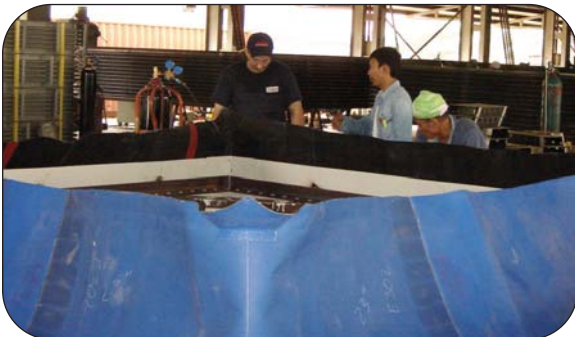

Thorburn's technician in Malaysia providing assembly training on a Flexi-Duct™ expansion joint for a Malaysian hot PA coal fired boiler



Thorburn Canada technician installing a KLF GSM on a Flexi-Duct™ sectioned outlet expansion joint for an HRSG in Huntstown, Ireland



Thorburn's Flexi-Duct™ expansion joint for a nickel smelter in Canada

Thorburn's Global Presence

The typical size of non-metallic expansion joints make it cost prohibitive to manufacture and supply them from a single location and service our clients worldwide. Thorburn leverages its extensive network of global manufacturing facilities to competitively manufacture its Flexi-Duct™ expansion joints in the country where the project is located. Thorburn's unique manufacturing strategy allows us to supply high quality, Canadian-engineered Flexi-Duct™ expansion joints and support its clients in every corner of the world.



Thorburn Mexico in Lázaro Cárdenas

Thorburn's Strategy for Project Execution & Scope

Thorburn Canada's scope includes engineering, estimating, procurement of metallic components (backing bars, frames, bolting), cavity pillow raw materials, fly ash barrier raw materials and gas seal membrane manufacturing, testing and development. Priority is placed on purchasing raw materials where the manufacturing is taking place. Raw materials are delivered to Thorburn's facility in the country where the expansion joints will be manufactured.



Thorburn South Africa in Johannesburg

Manufacturing of the metallic frames and expansion joint assembly is performed in one of Thorburn's global manufacturing centers or at one of Thorburn's partner facilities as close to the jobsite as possible. Thorburn's step-by-step manufacturing procedures (visual inspection, packaging, GSM splicing, cleaning, painting, welder qualification & welding procedures) and processes (plate bending, hole punching, angle & plate rolling, press-break, shearing, etc.) and expansion joint final assembly are strictly controlled and uniformly applied throughout Thorburn's global manufacturing network. Quality control is independent of manufacturing and its objective is to insure that all Thorburn's client contract requirements are met and Thorburn's manufacturing processes and procedures are strictly followed.

Thorburn's Added Value

This client-focused strategy enables Thorburn to cost effectively supply even the largest Flexi-Duct™ expansion joints in a timely manner to meet and exceed customer expectations for quality and value.



Thorburn Malaysia factory in Seremban

Thorburn Site Services



Thorburn's engineering team is highly experienced in both design and analysis of critical expansion joint applications



Thorburn's technician recording temperature of a penetration seal at an HRSG in Oregon, USA



Thorburn's engineer providing site training and failure mode analysis of a high temperature inlet expansion joint in an HRSG in Singapore

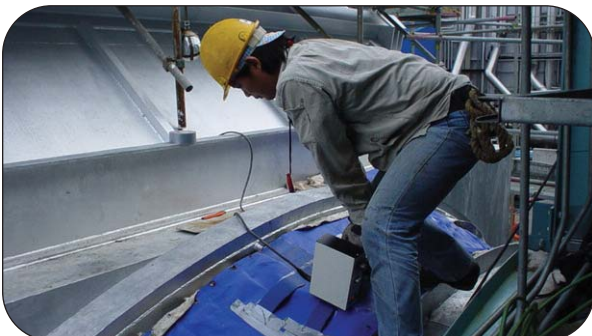

Thorburn Malaysian site team providing training on the proper procedures of splicing a KLF GSM at Malaysian gas fired power plant

Commitment to Superior Expansion Joint Design

Thorburn's engineers use advanced software to support their expansion joint designs and identify thermal and mechanical stresses found in flexible piping & ducting systems which affect the design.

Failure Mode Analysis

Thorburn's engineers can also provide on-site engineering services such as failure mode investigation analysis. Finite Element Analysis (FEA) can measure the results against the actual failure mode and Thorburn can recommend the appropriate counter measure.

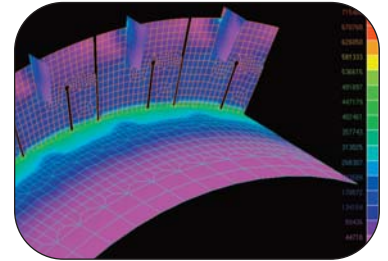

Thorburn's engineers use FEA for evaluating mechanical and thermal stress in Flexi-Duct expansion joint components to improve design and performance

Site Preventative Maintenance

Too often, failing expansion joints are not identified and become reactive maintenance items and unaccounted for in plant outage budgets. This is a major concern for plants operating within a budget or to complete work within a short outage time frame.



Thorburn's Site team measuring the temperature of an expansion joint's mating structure in an HRSG in Kansas, USA

Thorburn's site team provides a solution by surveying all the expansion joints and processes the data, section by section, into an informative site report. Using thermal imaging cameras, Thorburn's site team collects data when the unit is hot and operating to determine a scheduled maintenance priority list. The maintenance priority list identifies each expansion joint by tag number, photo, temperature reading and notes of concern. The list also provides a cost repair analysis which can be planned and budgeted for the next plant scheduled outage.

Site Maintenance Training

Thorburn offers training in expansion joint maintenance and repair to ensure the fit form and function of our Flexi-Duct™ expansion joints. Training highlights include, GSM belt splicing, early detection of failing expansion joints, proper installation of penetration seals, water draining concerns and thermal degradation prevention.



Thorburn's Site team providing expansion joint installation training in Tuxpan, Mexico

Thorburn Installation Commissioning Supervision



Thorburn installed a Flexi-Duct™ GTEJ-CC gas turbine exhaust expansion joint in Missouri USA

Thorburn has a site team of technicians, located in North America, South America, Europe, South East Asia and Africa, which are capable of supporting our Flexi-Duct™ expansion joints globally. The size of Thorburn's Flexi-Duct™ expansion joints often requires them to be shipped in sections and assembled at the job site. The proper assembly and installation of Thorburn's Flexi-Duct™ expansion joints are extremely important factors in their performance and longevity.



Site assembled Thorburn Flexi-Duct™ at a coal fired power plant in Malaysia

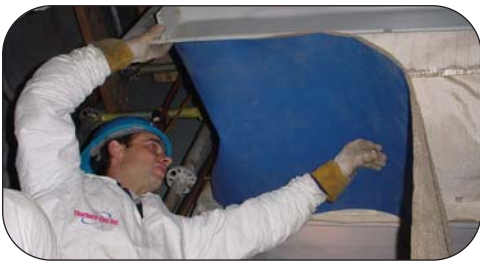

Thorburn's site technician demonstrating the proper method of installing a KLF GSM on a corner of a Flexi-Duct™ expansion joint

Contractors are not typically expansion joint specialists. Thorburn's site technicians can provide valuable instruction in GSM splicing, Flexi-Duct™ assembly, installation and final inspection on site. An expansion joint should never be treated as a commodity. If the design, manufacturing and installation are perfectly aligned, many years of maintenance free operation can be realized.



Thorburn's site team inspecting a section of a Flexi-Duct™ expansion joint before final assembly at a gas fired power plant in Australia

Thorburn GSM Development & Testing

Thorburn's GSMs, were developed through rigorous step by step testing programs and have been successfully used in expansion joint flue duct service since 1990. Thorburn's GSM materials have been awarded the Chemical Processing Vaaler Award and The Dupont Plunket Award for innovation in PTFE technology. They meet all the rigid quality requirements of the Fluid Sealing Association (FSA latest edition) and European Sealing Association (ESA latest edition).



ASTM D2176 Cyclic Flex Testing of Thorburn's TLFP GSM



ASTM E596 Acoustic Impedance Testing of Thorburn's Flexi-Duct™ HRSG inlet expansion joint

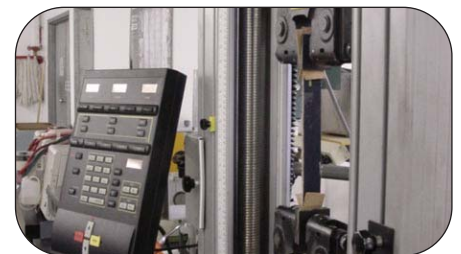

ASTM D751 Tensile Testing of Thorburn's K12 GSM



ASTM D4969 - 17 Chemical Testing of Thorburn's TLFP 40 GSM



ASTM C411 Cold face GSM and bolt thermal testing of Thorburn's KLF GSM without added insulation



ASTM C-411 Thermal Testing of Thorburn's KLFC GSM with no added insulation to 1100°C

Flexi-Duct™ Ducting Expansion Joints



Thorburn's Flexi-Duct™ Advantages

- **Large Movements:** Multi-plane movements in a shorter face-to-face.
- **Thermally Efficient:** Minimum heat loss
- **Low Loads:** Low spring rates generated from movements.
- **Corrosion Resistance:** Outstanding corrosion resistance in the most challenging scrubber applications.
- **Torsion:** Absorbs torsion movement caused by differential heating of the duct
- **Noise Reduction:** Reduces sound transmission
- **Easy Replacement:** Site replaceable and repairable

Thorburn Flexi-Duct™ Typical Expansion Joint Components

- 1 **Gas Seal Membrane (GSM)**
Withstands system pressure, temperature, corrosion & absorbs required movements.
- 2 **Insulating Layers**
Thermal protection, acoustic barrier and reduces condensation.
- 3 **Insulating Retainer Layer**
Keeps the insulating layers in place in order to maintain thermal integrity.
- 4 **Back-Up Bars**
Applies clamping pressure to create the fabric-to-duct seal.
- 5 **Metal Liner & Fly Ash Barrier**
Protects the GSM & insulating layers from particle abrasion, flutter and accumulation of ash in the expansion joint cavity.
- 6 **Cavity Pillow**
Prevents accumulation of particles in the expansion joint cavity and reduces acid attack during outage cooling
- 7 **Attachment Flanges**
Required to connect the flexible element to the ductwork.

What is a fabric expansion joint?

Fabric expansion joints compensate for duct misalignment and duct thermal growth. Fabric expansion joints are used to convey hot media in low pressure applications such as “in flowing air” and “out flowing gas” in large combustion processes and also act as vibration isolators, shock absorbers and make up for minor duct misalignments.

How does a fabric expansion joint work?

A fabric expansion joint is inserted into the ductwork where the movement will occur. It has three main components, a fabric gas seal membrane (GSM), insulation and metallic frames. As the ducting moves, the GSM will deform without tearing or leaking while being exposed to high temperatures and corrosive media.

What is a Flexi-Duct™ expansion joint?

Thorburn's Flexi-Duct™ expansion joints are engineered custom built using the most advanced composite material technology combined with proven expansion joint design. Our innovative Flexi-Duct™ expansion joints puts Thorburn in the best position to address thermal, chemical and multi-plane movement requirements in the most challenging flue duct applications. The following section describes the basic Flexi-Duct™ expansion joint components and what they are used for.

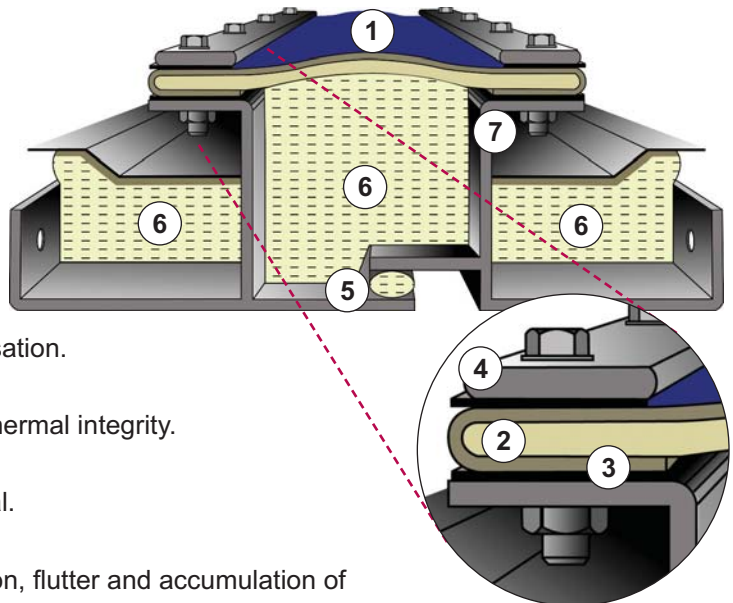

Thorburn Flexi-Duct™ Typical Markets & Applications



Power Generating

- Turbine Exhaust
- Diverter Inlet
- Bypass Stack
- Inlet HRSG
- Outlet HRSG
- Penetration Seal



Fossil Fuel

- Economizer
- Air Heater
- Loop Seal
- Windbox
- Precipitator
- Scrubber

Combined Cycle Combustion Turbine (CT)

CT outlet expansion joints in Peaker Plants are experiencing many more thermal cycles per year and higher operating temperatures. One way to improve operational reliability, lower operating costs and increase service life is to invest in Thorburn's Flexi-Duct™ CT expansion joints. Flexi-Duct™ CT expansion joints are made with the latest advancements in design engineering combined with the most technologically advanced materials yielding a longer service life.

There are three main CT manufacturers,

- GE (Frame 5, 6B, 7F & EA)
- Siemens (501FC, D, D2, D5A & 501G)
- Mitsubishi (501F, 501G & 701).



Thorburn Flexi-Duct™ CT outlet expansion joint

Flexi-Duct™ Expansion Joints For Wet Scrubber Service

This application covers a range of equipment and ducts that remove particulates and corrosive media from the flue gas. Thorburn's Flexi-Duct™ TLFP GSMs are made only of PTFE films that are impervious to chemical attack from this extremely challenging and corrosive application.



Thorburn Flexi-Duct™ TLFP GSM expansion joint for wet scrubber service

Other Flexi-Duct™ Applications

Material Processing

- Fume Control
- Heat Recovery
- Exhaust Gas & Air
- Process Gas & Air
- Precipitator
- Scrubber

Refinery

- Co Boiler
- Precipitator

Pulp & Paper

- Boilers
- Scrubber

Additional Flexi-Duct™ market applications see pages 24-35

Flexi-Duct™ Composite (FDC) & Elastomeric (FDR) Expansion Joints

Thorburn's Flexi-Duct™ expansion joint designs will fall into two basic types; composite (FDC) and elastomeric (FDR). These configurations can be either a round, oval or rectangular. An important consideration in selecting Thorburn's Flexi-Duct expansion joint is the system temperature. There are two classifications: those operating under 204°C (typically either FDC or FDR) and those operating above 204°C (only FDC).



Thorburn's Composite Series FDC expansion joint GSMs are typically designed for ducting systems with temperatures above 204°C (400°F)



Thorburn's Elastomeric Series FDR expansion joint GSMs are typically designed for ducting systems with temperatures below 204°C (400°F)

Thorburn's Composite (FDC) GSM

Thorburn's Gas Seal Membranes (GSM) are the flexible seal of Thorburn's Flexi-Duct expansion joints. Thorburn's GSMs are non-porous composites consisting of Thor-Coat 1200™ PTFE coated fiberglass (load bearing component) that has one side laminated to TLFP multiple layers of thin PTFE film (corrosion barrier). Thorburn's GSMs are specifically designed to contain the duct system's design pressure, absorb mechanical vibration & thermal movements and are non-permeable to pressurized gasses and liquids making them the ultimate in non-metallic flexible seals.

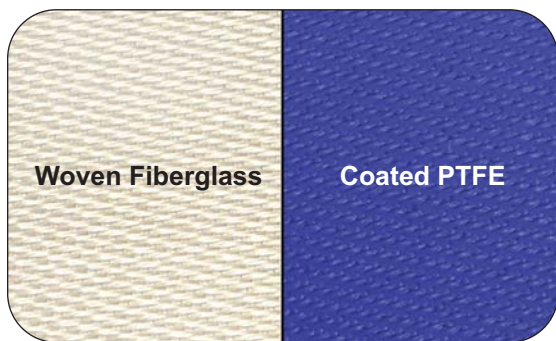
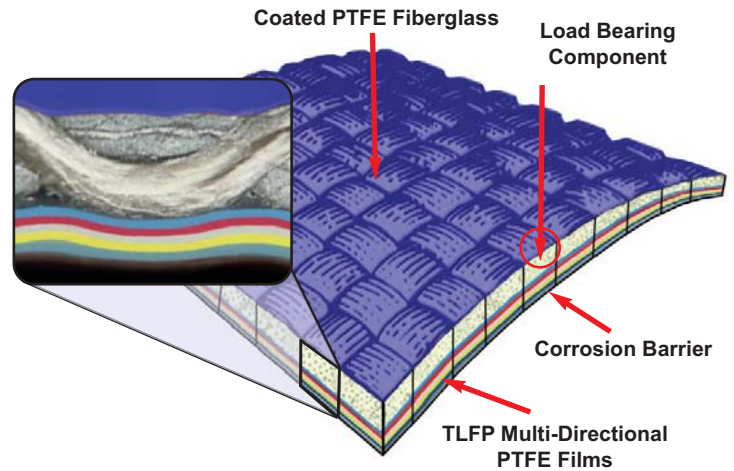

Thor-Coat 1200™ PTFE Coated Fiberglass

Thor-Coat 1200™ PTFE Coated Fiberglass

Thor-Coat 1200™ consists of a high tensile woven fiberglass which is heavily coated with PTFE using a proprietary coating system to create the load bearing component of Thorburn's GSMs. Thor-Coat 1200™ is engineered for high temperature, mechanically demanding expansion joint service.

Thor-Coat 1200™ Specifications

Temperature (MCOT): 316°C (600°F)

Weight: 1628 g/m² (48 oz/yd²)

Thickness: 1.00mm (0.040")

Width: 1524mm (60")

Tensile Strength - Warp: 10508 N/50mm (1200 lbs/in)

Tensile Strength - Fill: 10508 N/50mm (1200 lbs/in)

TLFP Corrosion Barrier

Thorburn's TLFP is the most corrosion resistant material found in the expansion joint industry. TLFP are thin films that are made from 100% pure PTFE resins. The thin TLFP films are crossed and then laminated into multi-directional layers to form a thick non permeable corrosion barrier without compromising flexibility and flex life. This combination makes TLFP chemically inert to any corrosive dry or wet flue gasses making it the worlds most popular expansion joint corrosion barrier. Thorburn's unique breakthrough TLFP technology provides the strength and corrosion resistance of a thick film and the flexibility of a thin film.

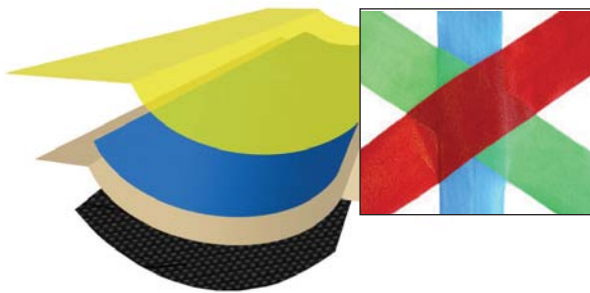

TLFP multiple layers of thin 100% pure PTFE laminated in cross directions



Thorburn's custom GSM with Thor-Coat 1200™ laminated to one side with 6 layers of TLFP

Thorburn's GSM Technology

Thorburn's GSMs incorporate all the latest advancements in material technology. Our sealed membranes utilize components that are impervious to chemical attack while providing tremendous flexing and thermal capabilities. These features provide a formidable, long term solution to wet or dry flue-duct sealing. The TLFP layers are crossed and laminated to produce a multi-directional based thicker corrosion barrier without compromising flexibility or flex life. All Thorburn's GSMs use Thor-Coat 1200™ technology and the amount of TLFP layers are their differentiating feature.

K12 Composite (FDC) GSM



Thorburn's K12 with Thor-Coat 1200 and 2 layers of TLFP

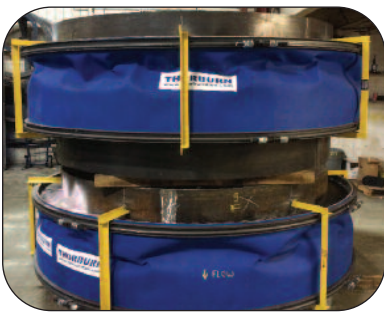

Flexi-Duct™ with K12 GSM for the Vale Clean AER Project Sudbury Canada

The Industry Standard For Flue Duct Applications

Thorburn's K12 GSM is our most widely used GSM material. It is constructed with Thor-Coat 1200™ PTFE coated fiberglass (load bearing component) which is anchored through a proprietary laminating process to multi-directional layers of TLFP film (corrosion barrier). K12 is non-porous and offers zero porosity to pressurized gasses. It is this unique combination of Thor-Coat 1200™ strength and TLFP corrosion resistance that makes the K12 the most advanced GSM in the world and the ideal choice for wet and dry flue gas service.

Tensile & Flex/Fold Test

Meets the breaking strength test as per ASTM D-751; Flex/fold test in accordance with ASTM D2176 with a maximum 30 flex-fold cycles.

K12 Specifications

- Materials of Construction:** Coated PTFE woven fiberglass c/w multiple layers of TLFP
- Temperature (MCOT):** 316°C (600°F) as per ASTM C-411 hot service test
- Weight:** 2034 g/m² (60 oz/yd²)
- Thickness:** 1.2mm (0.047")
- PTFE Coating:** 305g/m² (9 oz/yd²)
- Corrosion Barrier Thickness:** 0.23mm (0.009")
- Tensile Strength (Warp):** 10508 N/50mm (1200 lbs/in) as per ASTM D-751
- Tensile Strength (Fill):** 10508 N/50mm (1200 lbs/in) as per ASTM D-751

M12 Gas Seal Membrane



Thorburn's M12 with Thor-Coat 1200 and 4 layers of TLFP



Flexi-Duct™ with M12 GSM and drainage system at a power plant in Alexandria, Egypt

The Ultimate In Corrosion Resistance For Wet Flue Duct Applications

Thorburn's M12 GSM incorporates all the features of the K12 GSM with two additional films (totalling four) of TLFP. The M12 uses the Thor-Coat 1200™ load bearing platform to anchor the TLFP layers. The added TLFP films increases the thickness and reduces permeability even lower than K12 without compromising flexibility and cycle life. Therefore M12's lower permeability is advantageous in applications where extremely corrosive flue gasses are present such as fluorine and other destructive gasses which commonly destroy other GSMs. There is no other GSM on the planet that combines the strength and corrosion resistance of M12.

Tensile & Flex/Fold Test

Meets the breaking strength test as per ASTM D-751; Flex/fold test in accordance with ASTM D2176 with a maximum 30 flex-fold cycles.

M12 Specifications

- Materials of Construction:** Coated PTFE woven fiberglass c/w 4 layers of TLFP
- Temperature (MCOT):** 316°C (600°F) as per ASTM C-411 hot service test
- Weight:** 2679 g/m² (79 oz/yd²)
- Thickness:** 1.52mm (0.060")
- Corrosion Barrier Thickness:** 0.51mm (0.02")
- Tensile Strength (Warp):** 10508 N/50mm (1200 lbs/in)
- Tensile Strength (Fill):** 10508 N/50mm (1200 lbs/in)

KLF12 Composite (FDC) GSM

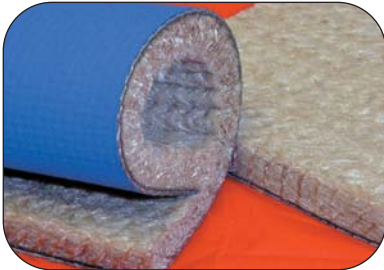

Thorburn's KLF12 PTFE Coated Fiberglass GSM

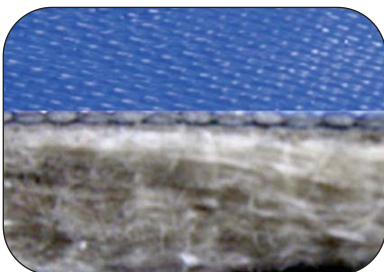

Cross-section view of KLF12 with 13.6mm laminated thermal barrier.



Flexi-Duct™ "U-Type" Expansion Joint with KLF GSM

Stand Alone Temperature Resistance To 538°C

Thorburn's KLF12 gas seal membrane has a maximum continuous operating temperature (MCOT) of 538°C (1000°F). The KLF12 is a composite flexible membrane consisting of all the features of the K12 GSM including the Thor-Coat 1200™ load bearing PTFE coated fiberglass fabric, 2 layers of multi-directional TLFP corrosion barrier on one side (gas side) with an added 13mm (1/2") laminated thermal barrier consisting of non-woven, fiberglass insulation with light PTFE coating.

The KLF12 Advantage

KLF12 is capable of resisting corrosion and stress cracking caused by flexing (as per ASTM D-2176 flexing test) and severe temperature fluctuation from -73°C to 538°C (-100°F to 1000°F).

The low strength non-woven fiberglass thermal insulation barrier is permanently anchored to the K12 GSM through a proprietary process. This unique process coats the KLF12 insulation with PTFE so that it "acquires" some of the high strength traits of the Thor-Coat 1200™ and the corrosion resistance of TLFP. This enables the KLF12 thermal insulation barrier to hold up longer in severe stresses encountered in flue duct seal applications, thereby extending the KLF12 service life compared to standard GSMs.

KLF12 Specifications

Materials of Construction:

Temperature (MCOT): 538°C (1000°F) as per ASTM C-411 hot service test

Intermittent Temperature: 593°C (1100°F)

Weight: 4103 g/m² (121 oz/yd²)

Overall Thickness: 13.7mm (0.54")

PTFE Coating: 610 g/m² (18 oz/yd²)

PTFE Barrier: 325 g/m² (9.6 oz/yd²)

Corrosion Barrier Thickness: 0.15mm (0.006")

Thermal Barrier Thickness: 13mm (0.5")

Tensile Strength (Warp): 10508 N/50mm (1200 lbs/in)

Tensile Strength (Fill): 10508 N/50mm (1200 lbs/in)

KLF12 Working Overtime For You

The KLF Advantage prevents Hot Spots:

Hot flue gas is unable to penetrate insulation materials because the thermal barrier is laminated to the K12 GSM which prevents hot spots

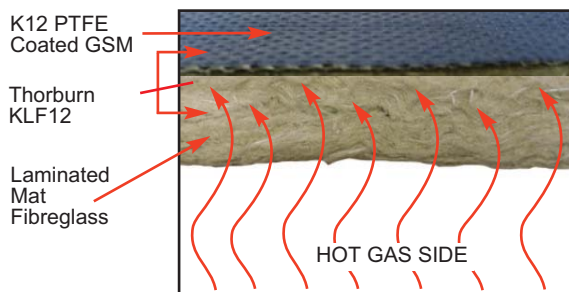

Inferior Designs Allow For Hot Spots:

Hot flue gas is able to penetrate insulation materials when they are used as "stand alone" components in composite expansion joints.

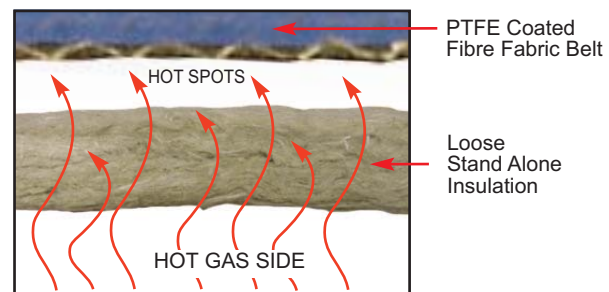

KLFC Composite (FDC) GSM



Thorburn's KLFC composite GSM with a stand alone temperature of 1100°C



Gas turbine exhaust expansion joint with Thorburn's KLFC GSM installed

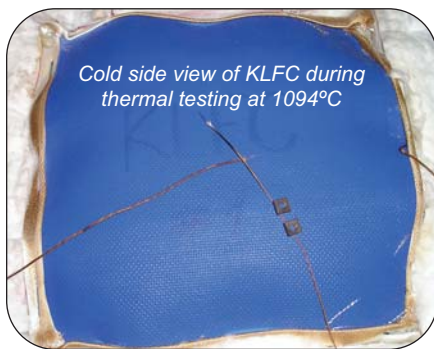

Thorburn's KLFC Composite GSM

Stand Alone Temperature Resistance To 1100°C

Thorburn's KLFC composite GSM is designed to withstand a maximum continuous operating temperature (MCOT) of 1100°C (2000°F), without additional cavity insulation. Inferior designs make the belt dependent upon the cavity insulation for their survival at high temperatures: please see the attached photo testing KLFC at 2000°F according to ASTM C-411.

KLFC Construction

The multi-directional corrosion liner is a 100% PTFE material that is capable of resisting the stress cracking caused by flexing as per ASTM D-2176 flexing test and severe temperature fluctuation. The thermal barrier is achieved through a laminated 1/2" thick fiberglass and ceramic fiber insulation blanket (thickness and density to meet stand alone temperature requirements). Optional vapor barriers are used to prevent due point condensation from attacking the insulation barriers. The thermal barrier is enveloped with a silica cloth, optional stainless steel or inconel wire mesh may be added to increase the tensile strength.

KLFC Specifications

Temperature (MCOT): 1100°C (2000°F) as per ASTM C-411 hot service test

Weight: 8935 g/m² (264 oz/yd²)

Overall Thickness: 38mm (1.5")

PTFE Coating: 610 g/m² (18 oz/yd²)

PTFE Barrier: 325 g/m² (9.6 oz/yd²)

Corrosion Barrier Thickness: 0.15mm (0.006")

Minimum Ceramic Insulation: 25 mm (1") / Density 96 kg/cu.m (6lbs/cu.ft)

Thermal Barrier Thickness: 13mm (0.5")

Tensile Strength (Warp): 10508 N/50mm (1200 lbs/in)

Tensile Strength (Fill): 10508 N/50mm (1200 lbs/in)

Thorburn's KLFC Thermal Testing

TUTCO Scientific performed temperature tests on Thorburn's KLFC as a stand alone thermal barrier consisting of a 13mm laminated fiberglass and 25mm of high density ceramic insulation. The hot side temperature of 1094°C the cold side temperature was 184°C. The 2nd test to simulate the exhaust temperature of a gas turbine with a hot side temperature of 648°C the cold side temperature was 99°C.

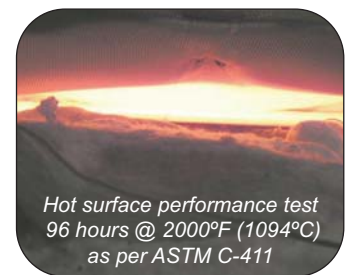

Hot surface performance test
96 hours @ 2000°F (1094°C)
as per ASTM C-411

Thorburn's KLFC GSM Flange & Clamping System



Flange & clamping detail

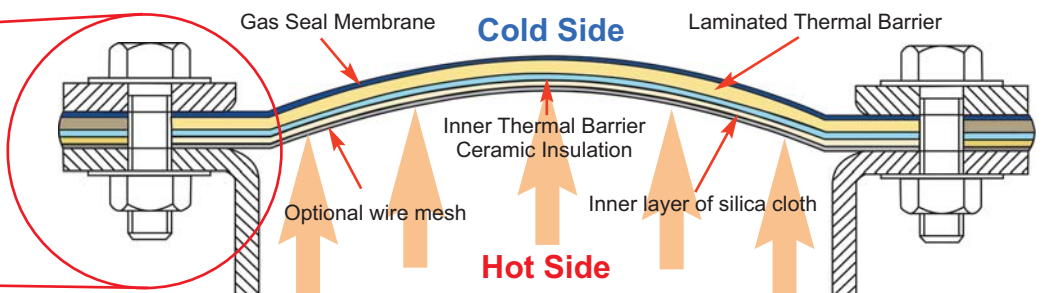

TLFP Series 40 & 60 Composite (FDC) GSMs

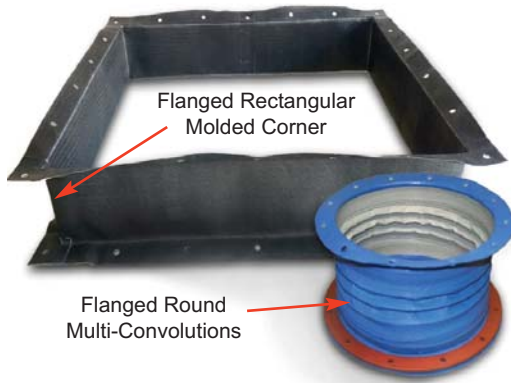

Flexi-Duct expansion joints made of only TLFP (multi-directional/layered PTFE)

The Ultimate In Corrosion Resistance Technology

TLFP Series 40 & 60 is made solely of PTFE resins. This stand alone PTFE GSM is completely resistant to chemical attack. TLFP Series 40 & 60 GSM's unique multi-layer, multi-directional strength provides stress crack resistance allowing it to be used as the flexible element in an expansion joint without the need for coated PTFE fiberglass reinforcement. TLFP Series 40 & 60, in its temperature and pressure range, will outperform any other GSM in terms of chemical resistance and fatigue failure.

When the concern for corrosion is eliminated in an expansion joint material, performance becomes more reliable and predictable. This benefit eliminates costly unplanned downtime from expansion joint failure. Thorburn's TLFP Series 40 & 60 GSMs can be molded into many shapes and sizes and provided in a conductive/anti-static condition.

TLFP Benefits:

- Thicker film ultimate corrosion barrier
- Exceptional flexing & fatigue performance
- Low permeation
- Zero porosity
- High Mechanical Capabilities
- Suitable for Applications Up To 260°C

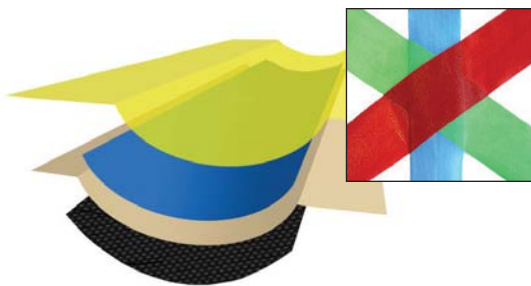

TLFP multiple layers of thin 100% pure PTFE laminated in cross directions



TLFP fabrication before layering



8 Layers of multi-directional TLFP without coated fiberglass reinforcement

TLFP 40 Specifications

Materials of Construction: 8 layers of TLFP
Temperature (MCOT): 260°C (500°F) as per ASTM C-411 hot service test
Weight: 2034 g/m² (60 oz/yd²)
Thickness: 1.02mm (0.04")
Corrosion Barrier Thickness: 1.02mm (0.04")
Tensile Strength: 1156 N/50mm (132 lbs/in)
Tear Strength: 472 N (106 lbs/in)



12 Layers of multi-directional TLFP without coated fiberglass reinforcement

TLFP 60 Specifications

Materials of Construction: 12 layers of TLFP
Temperature (MCOT): 260°C (500°F) as per ASTM C-411 hot service test
Weight: 3052 g/m² (90 oz/yd²)
Thickness: 1.52mm (0.06")
Corrosion Barrier Thickness: 1.52mm (0.06")
Tensile Strength: 1664 N/50mm (190 lbs/in)
Tear Strength: 676 N (152 lbs/in)

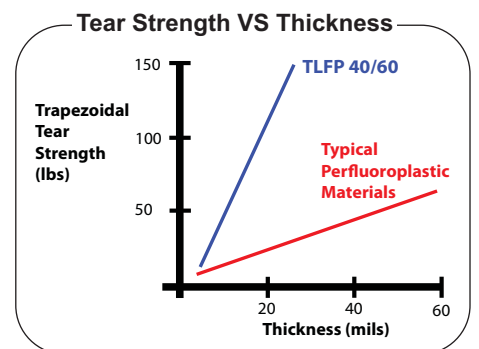

TLFP Technology

Breakthrough technology permits thick PTFE liners to be used in expansion joint service without the fear of stress cracking due to severe operating conditions. TLFP 40/60, as shown in the comparison chart above, is a different perfluoroplastic altogether.

Shutter-Flex™ Series SFX Composite (FDC) GSM

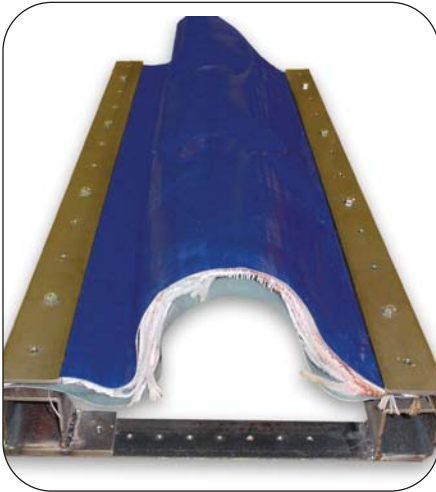

Cross Section of Thorburn's Shutter-Flex™

Shutter-Flex™ Neutralizes Fluttering

Thorburn's Shutter-Flex™ is engineered for turbulent flue gas conditions. Standard PTFE based GSMs by nature are low in weight and extremely flexible at elevated temperatures. These characteristics make them susceptible to fluttering (like a flag in the wind) resulting in flexing fatigue failure in extremely turbulent flue gas conditions. Typically, flow liners are used as the first defense against these conditions. When liners are not enough or cannot be used Thorburn's Shutter-Flex™ is an ideal GSM because it is manufactured with a high weight making it unmovable for extremely turbulent flue gas service yet flexible enough to absorb vibration, thermal or mechanical movements.

Shutter-Flex™ Construction

Thorburn's Shutter-Flex™ contains interior and exterior PTFE components that serve primarily as a corrosion barrier and, to a lesser extent, as a load bearing component. The internal components consist of high temperature fiberglass materials—products relied upon for their strength and weight. The multi-layered assembly performs as a single membrane because all plies are locked together by strategically located TLFP thermal welds.



Flexi-Duct expansion joint with Shutter-Flex™ technology

Shutter-Flex™ Specifications

Construction: TLFP (PTFE Resins) & Fiberglass

Temperature (MCOT): 316°C (600°F) as per ASTM C-411 hot service test

Weight: 16.32 kg/m² (30 lbs/yd²)

Overall Thickness: 50mm (2") Maximum

Tensile Strength (Warp): 35000 N/50mm (4000 lbs/in)

Tensile Strength (Fill): 35000 N/50mm (4000 lbs/in)

Note: Thinner membranes and other construction available depending upon application

Thorburn's GSMs Bias Weave Format



Thorburn's Bias Weave Format

Square Weave vs Bias Weave Format

Thorburn's GSMs bias weave format technology allows for 30% elongation compared to 3% standard square weave technology of our competitors. The increased elongation capabilities of Thorburn's bias format technology significantly extends the life of Thorburn's GSMs, reduces stress in "U" type expansion joints and in rectangular expansion joint corner designs.



Standard Square Weave Format

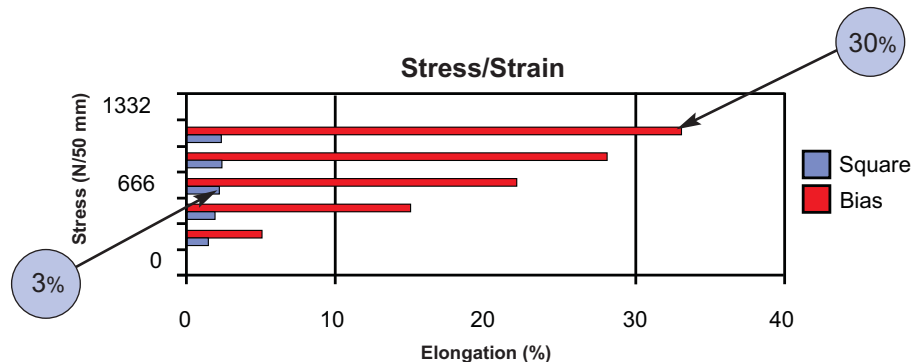

Thorburn's Flexi-Duct™ Elastomeric Flue & Air Duct Expansion Joints

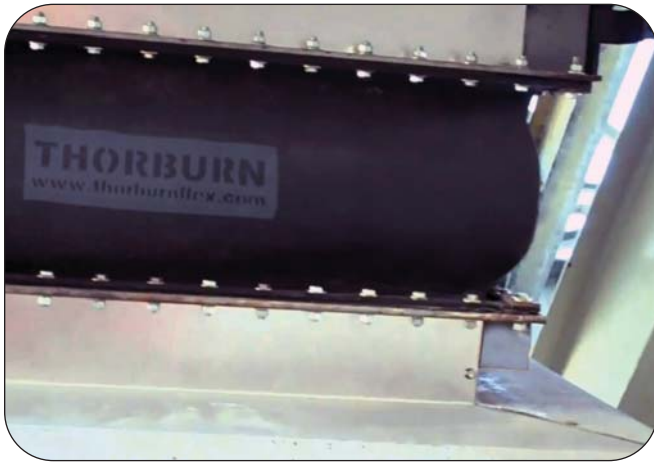

Thorburn Flexi-Duct™ Model 15R-LP Integral moulded “U-Type” flanged expansion joint installed on a fan outlet in an HVAC air handling system

Thorburn's Flexi-Duct™ Elastomeric “U-Type” Models 15R-LP & 15RA-LP (arch) flanged expansion joints are available in a flat, single and multi-arch designs. The standard applications are located close to the fan, blower, inlet and outlet where sound and vibration absorption are required. The flanges are customized to match the fan & blower inlet & outlet flanges. Available materials are EPDM, FKM, Silicone, Chloroprene, White FDA EPDM

- Absorbs vibration, thermal movement & shock
- Square, rectangular, oval & round designs
- Pressure up to $\pm 35\text{kPa}$ (5psi)
- Available in 2 ply & 4 ply designs



Thorburn Flexi-Duct™ Model 15RA-LP single arch Integral moulded “U-Type” flanged expansion joint

Thorburn's FDR Elastomeric GSMs

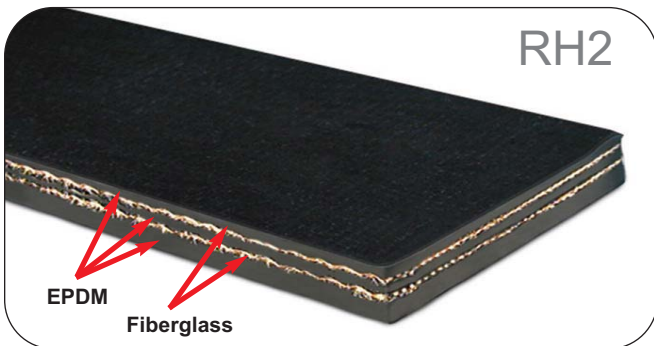

Thorburn's RH2 2 Ply High Tensile Fiberglass EPDM GSM

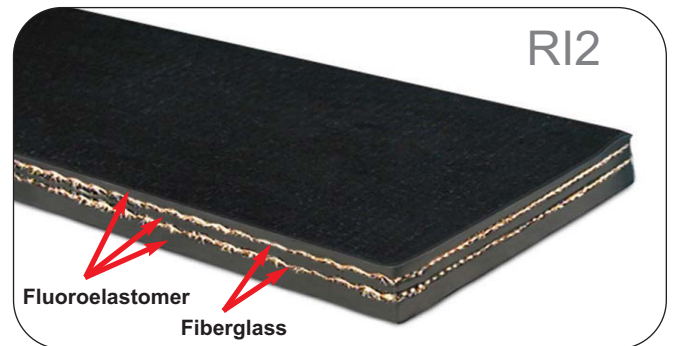

Thorburn's RI2 2 Ply High Tensile Fiberglass Fluoroelastomer (FKM) GSM

Thorburn's RH2 EPDM GSM provides outstanding resistance to ozone and has a 60 year shelf life which makes it a durable and longer lasting GSM. Thorburn's RH2 is also very resistant to oxidizing chemicals such as sulphuric acid and has a low temperature rating of -53°C

Thorburn's RH2 Specifications

- Specification:** M6CH610A25B14 as per ASTM D-2000
- Thickness:** 0.250" (± 0.025 ")
- Continuous Operating Temperature:** 300°F
- Intermittent Operating Temperature:** 350°F
- Gas Ply Thickness:** 0.062"
- Outer Ply Thickness:** 0.062"
- Hardness, Durometer Shore "A":** 60 (± 5) as per ASTM D-2240
- Tensile Strength (Min):** 1,450 PSI as per ASTM D-412
- Tensile Strength (Warp):** 240 lbs/in
- Tear Strength (Weft):** 450 lbs/in

Thorburn's RI2 Fluoroelastomer GSM is a high performance GSM with outstanding resistance to chemicals, oils & heat compared to any other elastomer. It is our premium elastomeric GSM and is ideally used in applications that require higher temperature resistance.

Thorburn's RI2 Specifications

- Specification:** FSA-DSJ-401-09 as per ASTM D-6909-10
- Thickness:** 0.265" (± 0.015 ")
- Continuous Operating Temperature:** 400°F
- Intermittent Operating Temperature:** 450°F
- Gas Ply Thickness:** 0.070"
- Outer Ply Thickness:** 0.050"
- Hardness, Durometer Shore "A":** 77 (± 5) as per ASTM D-2240
- Tensile Strength (Min):** 1015 PSI as per ASTM D-412
- Tensile Strength (Warp):** 240 lbs/in
- Tear Strength (Weft):** 450 lbs/in

Flexi-Duct™ Elastomeric (FDR) Ducting Expansion Joints



Thorburn's FDR "U" No Arch Type 15R-LP offers a smooth bore lining with integral flanges. They are available in round and rectangular styles and incorporate backing rings which provide the required compression force on the integral flanges to yield a leak tight seal without any additional gaskets. The standard GSM are 2 ply 6mm (1/4") thick which provides the thickness and weight required to offset flutter damage.

Size	Axial Compression	Axial Extension	Lateral Deflection
150mm (6")	19mm (0.75")	6mm (0.25")	13mm (0.5")
230mm (9")	32mm (1.25")	6mm (0.25")	19mm (0.75")
305mm (12")	51mm (2")	13mm (0.5")	25mm (1")
405mm (16")	76mm (3")	13mm (0.5")	38mm (1.5")

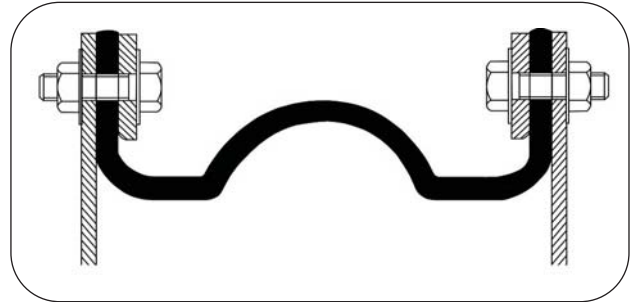

Thorburn's FDR "UA" Arch Type 15RA-LP provides greater movements in a shorter face-to-face. The arch is molded into the GSM which provides even lower spring rates than Thorburn's "U" Type FDR. During movement flexing, the arch absorbs the movement without the GSM entering the gas stream. Available with integral flanges to facilitate bolting and sealing and multiple arch designs when greater movements are required.

Size	Axial Compression	Axial Extension	Lateral Deflection
150mm (6")	57mm (2.25")	32mm (1.25")	32mm (1.25")
230mm (9")	76mm (3")	38mm (1.5")	51mm (2")
305mm (12")	102mm (4")	51mm (2")	64mm (2.5")
405mm (16")	127mm (5")	70mm (2.75")	76mm (3")

Thorburn's Elastomeric Expansion Joint Molded Corner Series "MC"



Thorburn's MC
Molded Corner

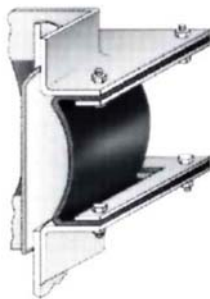

Thorburn's MC-WL
Molded Corner with
Weld-In Flow Liner

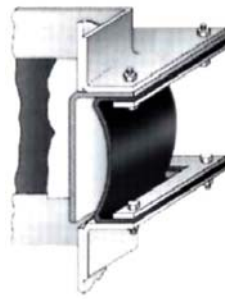

Thorburn's MC-BL
Molded Corner with
Bolt-In Flow Liner

Designed for square or rectangular ducting systems

Thorburn Type MC features integrally molded reinforced elastomeric expansion joint corners. One of the major problems connected with ducting expansion joints has been the tendency to fold or pucker at the corners. The main way to stress a rubber compound to failure is to bend it at a sharp angle and maintain that stress in the presence of heat and chemical attack.

The central idea of Thorburn's U/UA Type is to make integral flanges in the GSM to serve as the attachment flange to the mating flange. The molded corners are designed to remove the corner stresses caused by the U/UA Type integral attachment flanges. Weld-in or bolt-on flow liners may be added when the medium contains erosive dust or heavy particulate matter. Like all Thorburn's U/UA Type designs, bolting is accessible from the exterior of the duct.

Typical Setback Heights FOR U/UA Type Expansion Joints

Breach Opening Installed Length	150mm (6")	230mm (9")	300mm (12")	400mm (16")
Setback Height				
Molded Corner Positive Pressure	75mm (3")	100mm (4")	100mm (4")	125mm (5")
Molded Corner Negative Pressure	125mm (5")	150mm (6")	175mm (7")	200mm (8")

Flexi-Duct™ GSMs, Backing Bars & Clamps

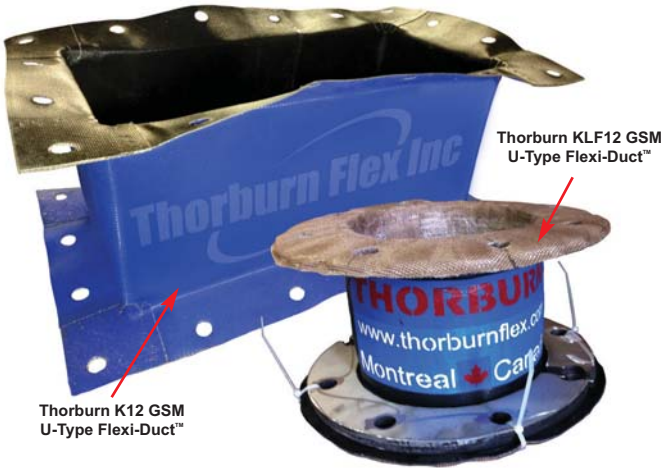

Thorburn "U" Type GSMs are typically sold as a stand alone product with backing bars and without frames

"U" Type Belt

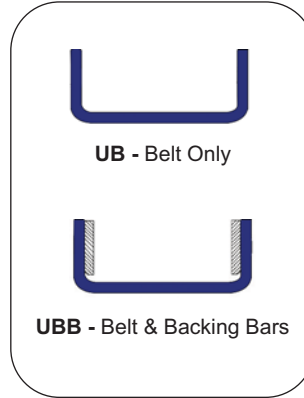

Flat Type Belt

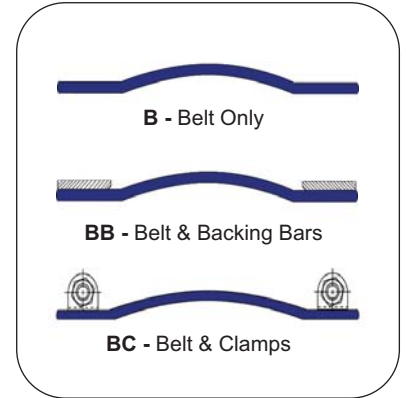

Flexi-Duct™ Flat GSMs with Typical Frame Configurations

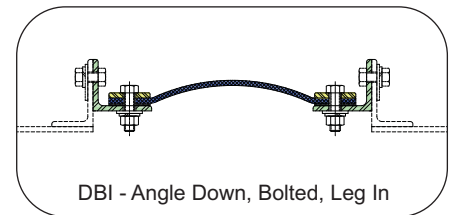
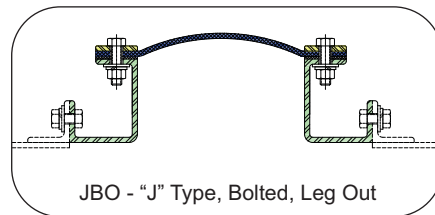
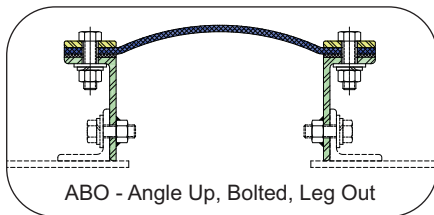
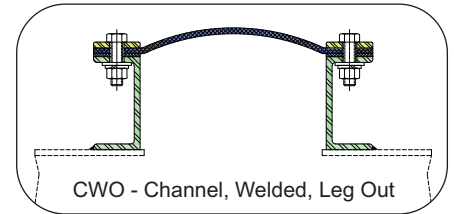
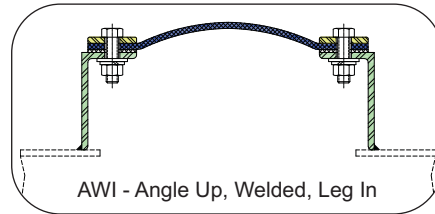
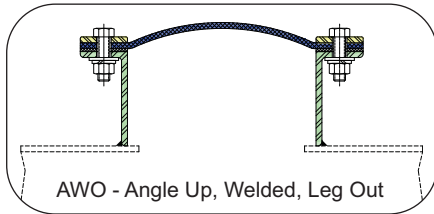

Flexi-Duct™ Frame Ordering Codes

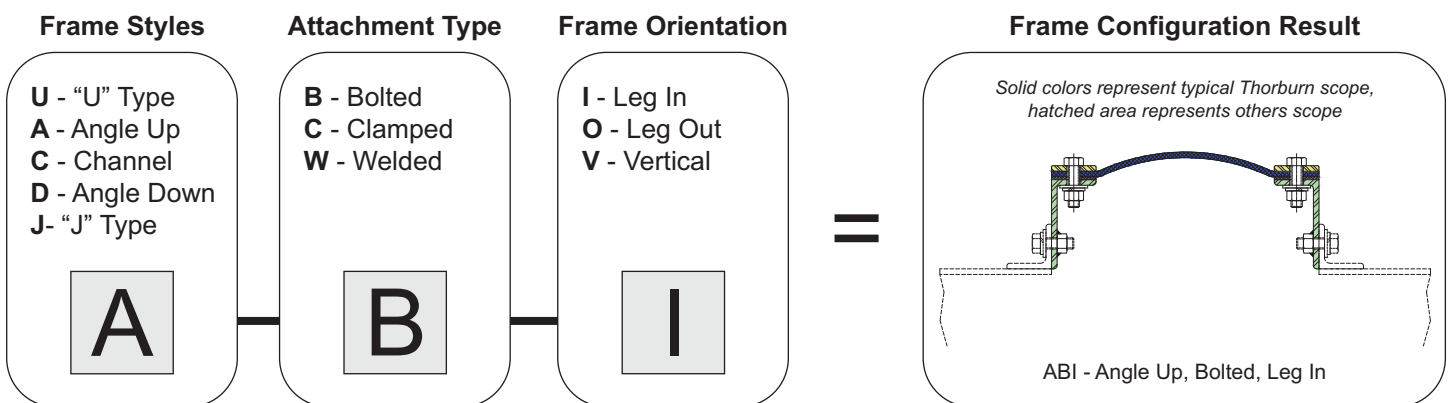

Flexi-Duct™ Flow Liner Systems

Thorburn flow liner (Baffle) systems are designed to protect the GSM from direct contact with particles suspended in the media which can cause deterioration. Flow liners are also used to reduce flutter of the GSM when the flow is turbulent or the fans are pulsating. The shape of a flow liner is an important design aspect to ensure that the expansion joint movement is not restricted. Thorburn's flow liner systems can be designed in various materials, thicknesses and typically fall into four typical designs and installations.

Thorburn's Flow Liner Typical Designs

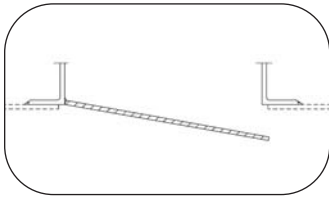

ST - Straight Design

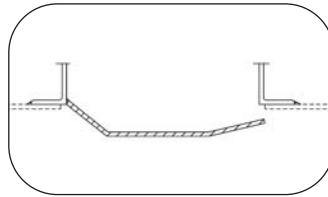

AF - Airfoil Design

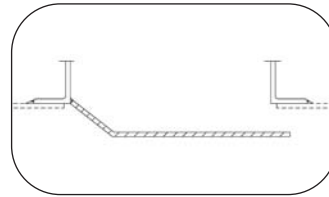

SA - Semi-Airfoil Design

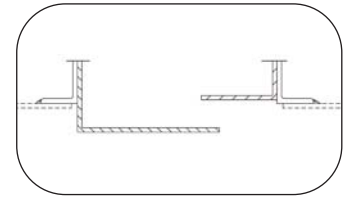

TL - Telescopic Design

Thorburn's Flow Liner Typical Installations

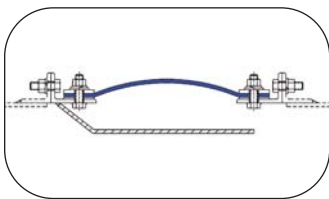

LWF - Weld-In Liner to Frame

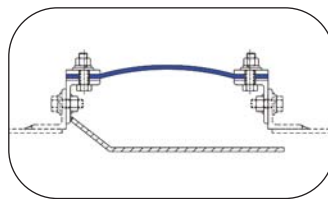

LWD - Weld-In Liner to Duct Plate

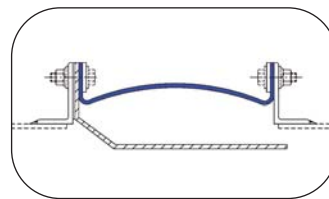

LBF - Bolt-In Liner to Flange

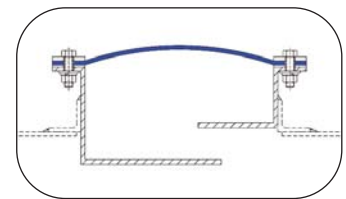

LIF - Integral Liner to Frame

Other important flow liner considerations are:

- The type and thickness of material in relation to erosion and corrosion.
- The length of each section of the flow liner must provide for thermal growth.
- Requirements for duct washing, the need to protect the cavity pillows & GSM
- Welded flow liners must accommodate temperature differentials
- The gap between the flow liners must not interfere with other components
- Flow liners must be designed not to entrap dust or condensation.



Thorburn's Channel frame with integral liner, pinned cavity pillow with retaining bag and fly ash barrier system

Flexi-Duct™ Backing Bars



Bolt-On Design

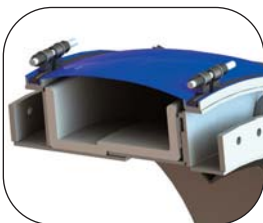

Clamp-On Design

Thorburn's backing bars are used to provide an even compression force to seal the GSM against the frame. We use two methods to attach the GSM to the frame which are bolt-on (Standard) and clamp-on designs (special order for round frames only). The backing bar bolt-on design depends on the bolt hole size, bolt spacing and flange width. Other types of Thorburn backing bars include "L" shaped, channels, straps and clamps which are designed to suit specific applications and design requirements.

Flexi-Duct™ GSM Bolt Spacing

To seal Thorburn's GSM to the duct flange, all flange bolt hole spacing are typically set at 100mm (4") center-to-center (C-C) spacing with 12mm (1/2") or 16mm (5/8") Bolts.



Thorburn's JBO frame showing 100mm C-C spacing with 16mm (5/8) bolting detail

Thorburn's corner bridge clamps are employed to support a uniform compression force between the split corner backing bars and the GSM

Corner Bridge Clamps

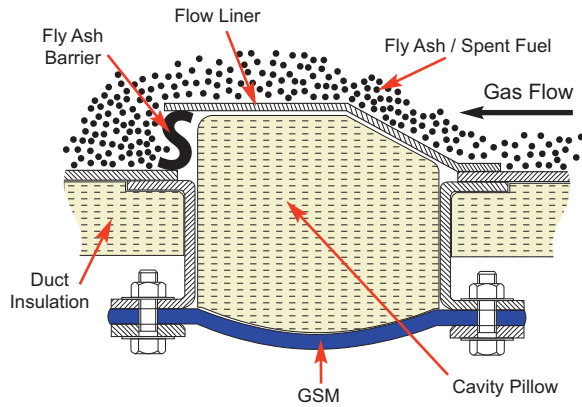

Flexi-Duct™ Cavity Pillow

The cavity between the GSM and the flow liner can accumulate with particles falling out of the flue gas. If these particles are allowed to build up within the cavity this will prevent the movement of the expansion joint. Thorburn's cavity pillow (also known as Bolsters) systems are designed to prevent ingress of solids into the cavity between the liner & GSM. In addition, Thorburn's cavity pillow systems also provide the following benefits.

- Additional thermal protection for the GSM
- Improves the acoustic performance of the expansion joint
- Minimizes the effects of pulsation or flutter by preventing the transmission of these variations to the GSM.

Construction

Thorburn's cavity pillow systems are constructed in a number of ways to accommodate application design conditions. They are typically formed by encasing fibrous materials into a retaining bag and securing it through a pinning system to either the expansion joint frame or the flow liner to prevent slippage. When extreme abrasion is present, layers of metallic mesh is used as a secondary retaining bag.

Thorburn's cavity pillows fall into two types, Series TBS 2600 ceramic fiber insulation for applications above 600°C and Series TBS 960 Mineral Wool insulation for applications below 600°C

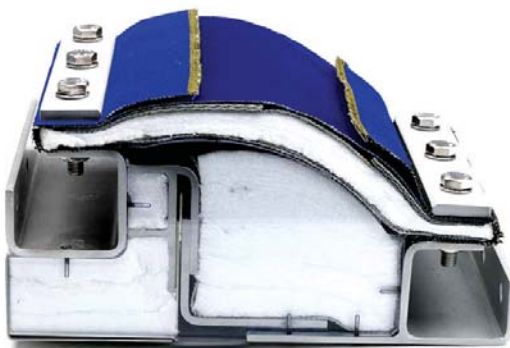

Integral flow liner

TBS 960 Hot Face & Cold Face Insulation Thickness Temperature Change



TBS 960 Insulation

Hot Face

Temperature	
°C	°F
149	300
316	600
538	1000

Insulation Thickness / Cold Face Temperature Results

102 mm	4 in	152 mm	6 in
°C	°F	°C	°F
36	96	31	88
55	131	43	110
88	191	65	149

TBS 2600 Hot Face & Cold Face Insulation Thickness Temperature Change



TBS 2600 Insulation

Hot Face

Temperature	
°C	°F
649	1200
871	1600
1093	2000

Insulation Thickness / Cold Face Temperature Results

102 mm	4 in	152 mm	6 in
°C	°F	°C	°F
80	176	65	149
115	238	91	196
158	317	125	257

All heat flow calculations are based on a surface emissivity factor of .90, an ambient temperature of 27°C (80°F) and zero wind velocity, unless otherwise stated. All thermal conductivity values have been measured in accordance with ASTM Test Procedure C-177. When comparing similar data, it is advisable to check the validity of all thermal conductivity values and ensure the resulting heat flow calculations are based on the same condition factors. Variations in any of these factors will result in significant differences in the calculated data.

Flexi-Duct™ Insulation Retaining Bag



Thorburn's TC-2000RB retaining bag with insulation build-up

Thorburn's insulation retaining bags also known as bolster bags encases the insulation materials of the expansion joint cavity pillow. Thorburn's insulation retaining bags offer protection against harmful non-respirable materials in the insulation, eases handling during installation and assists in securing the cavity pillow to the expansion joint frame. Thorburn also adds metallic mesh which protects the exposed bottom layers of the cavity pillow to minimize damage to the fibrous materials caused by abrasion. Thorburn expansion joints typically use two types of insulation retaining bags depending on application and temperature requirements.



Thorburn's TC-2000RBW** Insulation Retaining Bag with wire mesh

Thorburn's TC-2000RB Series MCOT 1100°C (2000°F)

Thorburn's TC-2000RB series insulation retaining bag is made of asbestos free alumina-silica ceramic fibers with inserted inconel wire to increase tensile strength. Thorburn's TC-2000RB has excellent resistance to corrosion attack, strong resistance to thermal shock, resists oxidation when wet by water or steam and thermal properties are restored upon drying.



Thorburn's TC-1000RB Insulation Retaining Bag

Thorburn's TC-1000RB Series MCOT 538°C (1000°F)

Thorburn's TC-1000RB series insulation retaining bag is made from 100% texturized fiberglass cloth: it has low thermal conductivity and is chemically stable, resisting attack from most alkalides and solvents.



Thorburn's TC-1000RB insulation retaining bag secured to expansion joint frame

**Note: Wire mesh is an option and the suffix "W" is used after the part number.

Flexi-Duct™ Fly Ash Barriers



Thorburn's engineer examining the ash barrier inside a large diameter HRSG inlet expansion joint with a 150mm offset opening at a Singapore power plant

Thorburn's typical cavity pillow is commonly used on high temperature, dry systems. When the flue gas has suspended moist or heavy fly ash an additional barrier is required. Thorburn's fly ash barriers are seals that include heavy duty hose braid made from stainless steel or inconel with enclosed ceramic insulation. Thorburn's fly ash barrier systems are not leak tight where minor ash or duct particles may penetrate the expansion joint cavity but not to a degree that would damage the GSM. Thorburn's engineers have the experience to calculate the ideal liner clearances and engineering the right combination of cavity pillow and a fly ash design to prolong the life span of Thorburn's GSM.



Thorburn's FAB-T Fly Ash Barrier Tadpole design with high temperature ceramic cloth encased in inconel wire mesh

Flexi-Duct™ PTFE Expandable Gasket Tape



Thorburn's JSGT
25mm width X 5mm thick

Thorburn's JSGT
10mm width X 3mm thick

Thorburn's JSGT PTFE Gasket Tape

is a widely tested and proven way to seal liquids and gases of any kind in wet or dry service. The highly fibrillated expanded PTFE exhibits flexibility, compressibility, stability under high temperatures, and high-tensile strength. The chemically inert gasket resists creep relaxation and maintains a seal at temperatures up to 316°C. Thorburn's series JSGT PTFE gasket tape is the ideal joint sealant for Thorburn's Flexi-Duct™ expansion joints using type K12, M12 & TLFP GSMs that require a flat sealant or full-face gasket.

Technical Specification

Material: 100% PTFE - Color White

Compressibility: ASTM F36-97

Creep Relaxation: ASTM F38B-95

DIN 3535 Gas Permeability*: 0.05 ml/min (Nitrogen Gas Permeation)

Conditions: Clamping pressure - 320bar, Internal pressure 40bar

Temperature Range: -240°C to 316°C

Chemical Resistance: Excellent

Standard Size: Thick 5mm, Width 13mm, Length 30mm (other sizes available)

* DIN 3535 Gas Permeability - measures leakage of a gas through a gasket.

Results: 72.2 %

Results: 24.5 %

pH Range: 0 - 14

Flexi-Duct™ High Temperature Treated Textile Gaskets



Thorburn's high temperature gaskets are tightly wrapped around the GSM and underneath and beyond the backing bars to reduce leakage and provide protection against heat and abrasion

Thorburn's GSMs can be considered leak tight however special attention should be drawn to the bolting and clamping areas to the metal frames where there is greater potential for leakage and thermal damage. Thorburn's high temperature gaskets provide a method to reduce (but not eliminate) leakage and thermal damage in the bolting and clamping areas. Widths (W) available in 50mm (Code 2), 63mm (Code 2.5) and 80mm (Code 3). Optional metallic inserts made of stainless steel (Code RS) or Inconel (Code RI) can be incorporated into the gasket for increased mechanical strength. Codes are inserted after the part number.

Thorburn Series GT-1000 up to 538°C

Thorburn's GT-1000 is made from textured fiberglass that will not fray, is wettable and reusable. In addition, it is highly resistant to chemical attack and will not flash or smoulder.



Thorburn's GT-1000-3-RS
3" wide gasket with SS wire
reinforcement

Thorburn Series GT-2300 up to 1260°C

Thorburn's GT-2300 is a ceramic woven textile gasket, specially treated to prevent fraying during cutting and fabrication; it is wettable and reusable. In addition, it is highly resistant to chemical attack and will not flash or smoulder.



GT-2300 Fiberglass Gasket

Thorburn's KLFC High Temperature GSM fitted
with GT-2300 Gaskets

Flexi-Duct™ With Pantograph Linkage

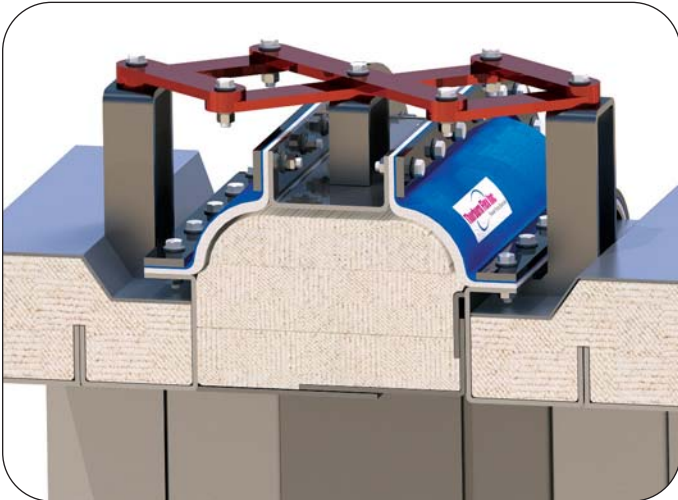

Thorburn's Flexi-Duct™ universal expansion joint with a pantograph control system can equally divide the movements between both flexible elements, reducing corner folds, allow for free convection and prolong the lifespan of the expansion joints.



Corner Folds



Hot Spots

Solution to High Temperature Corner Folds

Conventional flat belt rectangular high temperature expansion joints that must absorb large amounts of axial and lateral movements can develop pronounced folds in the GSM at the corners of the expansion joint. These pronounced folds prevent free convection and reduce cooling of the GSM's outer membrane causing hot spots and eventual burnout resulting in premature failure.

Flexi-Duct™ Integral Drainage Systems



Thorburn's M12 GSM with integral drains on the bottom of a rectangular Flexi-Duct™ expansion joint complete with flex hoses and ball valves at an Egyptian power plant

When the ducting systems are active the flue gas is typically dry. In low temperature applications or when the system is down due to an outage, the flue gas becomes moist and extremely corrosive. When pooling of corrosive fluids occur, Thorburn's Flexi-Duct™ expansion joints can include an integral drainage system. These systems are typically installed at the bottom of the Flexi-duct expansion joint, integrally molded into Thorburn's K12, M12 or TLFP GSMs. Drainage systems also include hoses and ball valves made of polypropylene, PVDF and PTFE to allow the corrosive fluids trapped in the expansion joints to be drained into a basin and removed.

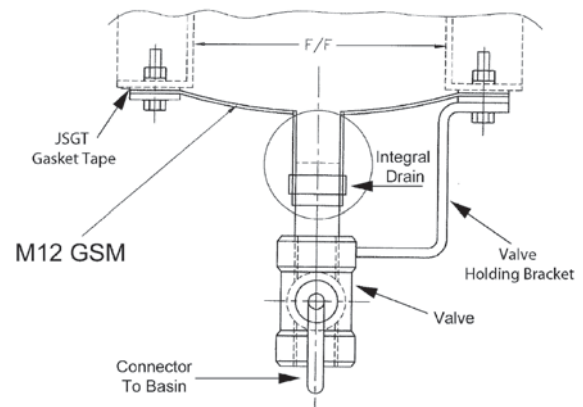

How to Order Flexi-Duct™ Expansion Joints

Thorburn's standard round and rectangular Flexi-Duct™ expansion joints can be specified or ordered by part number. Completion of the "Expansion Joint Specification Sheet", on page 42, will help determine the correct part number. Follow the instructions below to complete Thorburn Flexi-Duct™ part number. Several examples have been selected to demonstrate different standard designs.

1	2	3		4	5	6	7		8	9	10			11
Model	Assembly Condition	GSM/Backing Bar Type		MCOT (°C)	System Operating Pressure	Frame Type	Liner Requirement		Active Length	Duct Size	Materials			Additional Instructions
		GSM	Backing Bar				Design	Installation			Frame	Liner	Backing Bar	
FDC	A	KLF12	F	350	NP	AWO	TL	LWF	12	1200X2500	S6	S4	CS	X
FDR	15R-LP	RH2	L	100	P	UBB	LP		6	1000		S6	S6	X

Additional Instructions X= Backing bars - 10mm X 40mm (3/8"X2 1/2"), Setback - 150mm (6"), Angle - 150mm X 80mm X10mm (6"X3"X3/8")

1. Model

FDC - Flexi-Duct Composite GSM

FDR - Flexi-Duct Rubber (Elastomeric) GSM

2. Assembly Condition

A - Assembled - Ready for immediate installation. Includes backup bars, nuts and bolts.

AS - Assembled Sections - Ready for immediate site assembly. Includes frame, liners, assembled with pillows, ash barriers backup bars, nuts and bolts.

U - Unassembled - Match-marked and packaged to minimize assembly at the jobsite.

BA - Belt, Assembled - Fabric belt elements are provided as a factory-spliced, endless loop, to fit existing frames.

BU - Belt, Unassembled - Fabric elements are prepared for splicing at the jobsite.

Factory holes, back-up bars, nuts and bolts must be specified in "Additional Instructions".

Elastomeric "U-Type" - Ready for immediate installation

15R-LP - Assembled including backup bars

15RA-LP - Assembled including backup bars

If backing bars are not supplied, specify in Additional Instructions

3. GSM & Backing Bar Type

TYPE FDC	MCOT	TYPE FDR	MCOT
K12	316°C	RH2 (2 ply EPDM)	150°C
M12	316°C	RI2 (2 ply FKM)	204°C
KLF12	538°C	RH4 (4 ply EPDM)*	150°C
KLFC	1100°C	RI4 (4 ply FKM)*	204°C
TLFP40	260°C	RL2 (2 ply Silicone)	250°C
TLFP60	260°C	RC2 (2 ply Chloroprene)	107°C
SFX	316°C	RH2W (2 ply White FDA EPDM)	150°C

* High pressure to +/-35kPa (5psi)

Backing Bar Type

F: Flat Bar

L: L Shaped

C: Channel

S: Strapping

U: U Clamp

4. MCOT (Maximum Continuous Operating Temperature)

This is the highest temperature at which the system normally operates. Excursion (upset) temperatures and durations should be specified in "Additional Instructions"

5. System Operating Pressure

P - Positive pressure only

N - Negative pressure only

NP - Negative and positive pressure

Maximum rated operating pressure: ± 21 kPa (±90 in. H₂O (±3 psig))

Higher pressure to be specified in Additional Instructions

6. Frame Type (Codes)

Metal Frames **Attachment Type** **Frame Orientation**

U - "U" Type

B - Bolted

I - Leg In

A - Angle Up

C - Clamped

O - Leg Out

C - Channel

W - Welded

V - Vertical

D - Angle Down

Note: Special frames insert XXX and specify

J - "J" Type

i.e. GTEJ-CC, GTEJ-HC, GTEJ-HH, etc.

Belt Frames Only (See page 15 for details)

UB - "U" Type Belt Only

UBB - "U" Type Belt & Backing Bars

UAB - "U" Type Belt, Arch & Backing Bars (Multiple arch specify)

B - Flat Belt Only

BB - Flat Belt & Backing Bars

BC - Flat Belt & Clamps

7. Liner Requirement (Codes)

Integral Liner Designs

ST - Straight Design

AF - Airfoil Design

SA - Semi-Airfoil Design

TL - Telescopic Design

Typical Liner Installations

LWF - Weld-in liner to frame

LWD - Weld-in liner to duct plate

LBF - Bolt-in liner to flange

LIF - Integral liner to frame

Other Liner Design Configurations

LP - Loose liner by Thorburn - shipped loose, properly sized and match-marked to minimize field installation.

(For liner installation type see above or leave blank).

LO - Liner by others. *(For liner installation type leave blank).*

NL - No liner. *(For liner installation type leave blank).*

8. Active Length

Active length (the working face to face dimension) defines the unrestrained width of the GSM, and is typically the distance between the inner edges of the back-up bars. This dimension determines the amount of movement the expansion joint is capable of absorbing.

Flexi-Duct™ Maximum Non-Concurrent Movements per Active Length

A difference exists between the movement capabilities of round expansion joints and large rectangular joints due to the folding characteristics of the GSM which vary depending on whether it is attached to straight or curved flanges. (See standard active lengths below).

Typical Non-Concurrent Maximum Movement Capabilities*

Active Length (mm)	Breach Opening/ Installed Length (mm)	Axial Compression (mm)		Axial Extension (mm)		Lateral Deflection (mm)	
		Rectangular	Round	Rectangular	Round	Rectangular	Round
150 (6")	140 (5 1/2")	25 (1")	25 (1")	12.7 (1/2")	12.7 (1/2")	±19 (±3/4")	±25 (±1")
230 (9")	216 (8 1/2")	51 (2")	51 (2")	12.7 (1/2")	12.7 (1/2")	±40 (±1 1/2")	±51 (±2")
305 (12")	280 (11")	76 (3")	76 (3")	25 (1")	25 (1")	±63.5 (±2 1/2")	±76 (±3")
405 (16")	380 (15")	102 (4")	102 (4")	25 (1")	25 (1")	±102 (±3 1/2")	±102 (±4")

Pre-offsetting the duct-work opposite the anticipated movement will yield greater movement. When little or no axial movement is specified, lateral capability can be obtained by precompressing the joint (and installing it at a shorter face to face dimension) or increasing flat belt width.

- * 1. Thorburn recommends the active length not exceed 405mm (16").
- 2. Breach Opening Tolerances: Axial: 1/4" (6mm) extension, 1/2" (13mm) compression Lateral: 1/2" (13mm).
- 3. If lateral movement exceeds 75mm (3"), the ductwork and/or expansion joint frame should be pre-offset one half the expected movement.

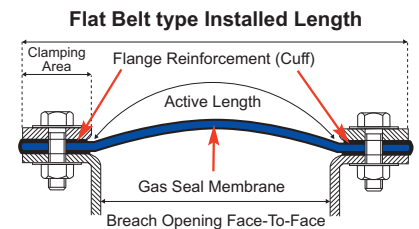
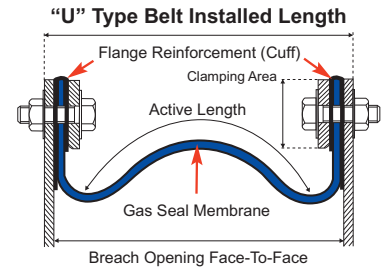

9. Duct Size

Assembled and unassembled assemblies: Size is specified as the inside duct measurements, in millimeters or inches, for both rectangular and round joints. Standoff height/setback, should be specified in "Additional Instructions". Setback is the distance the flexible element is moved outward from the gas stream to allow for system movements and to prevent the GSM from protruding into the gas stream or rubbing on the flow liner when operating under negative pressures. Proper setback also reduces the thermal transfer effect on the inner face of the GSM and prevents abrasion from particles in the gas stream. Integral flange height is min. 80mm

Belt Only Designs: If only the GSM is supplied the attachment flanges should be specified. The GSM length must exceed the peripheral distance to fit the duct size. The GSM will be supplied as a closed loop with a factory splice or as an open ended GSM.

Typical Setback Requirements

ACTIVE LENGTH	6" (150mm)	9" (230mm)	12" (305mm)	16" (405mm)
SETBACK:				
Flat Belt Positive Pressure	3" (75mm)	3" (75mm)	4" (100mm)	6" (150mm)
Flat Belt Negative Pressure	4" (100mm)	6" (150mm)	6" (150mm)	7" (175mm)
Integral Flange Positive Pressure	1" (25mm)	1 1/2" (38mm)	2" (50mm)	2 1/2" (63mm)
Integral Flange Negative Pressure	2" (50mm)	3" (75mm)	4" (100mm)	5" (125mm)

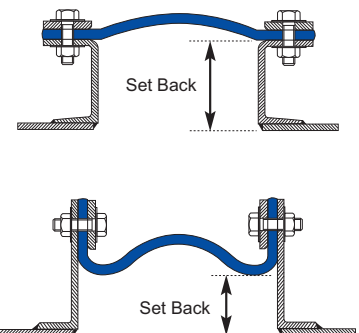

10. Materials - Frame, Liner & Backing Bar

- CS** - Carbon Steel A36/44W
- CA** - Corten A
- CM** - Carbon Alloy Steel 16Mo3
- S6** - Stainless Steel 316
- S4** - Stainless Steel 304
- XM** - Specify Material

11. Additional Instructions

Adding the suffix "X" at the end of a Flexi-Duct™ part number allows for special requirements that can have a written description for example X=Integral Drain Attachment, Fly Ash Barrier, Special Painting Instructions, Tack Welded Nuts, Corner Radius, etc.

Flexi-Duct™ HRSG Plant Expansion Joint Applications



An HRSG system consists of four major components: the economizer, evaporator, superheater and water preheater. The HRSG recovers the waste heat available in the combustion turbine exhaust gas. The recovered heat is used to generate steam at high pressure and high temperature to run other turbines.

Expansion Joint Application

P G I H D				
Equipment	Media	Location	Particulate	Wet/Dry
A = Air Heater B = Boiler C = Chimney/Stack D = Diverter E = Economizer F = Forced Draft Fan G = Gas Recirculation Fan H = Heater I = Induced Draft Fan P = Precipitator M = Coal Mill S = Scrubber T = Turbine U = Main Fan V = HRSG X = Turbo Expander Y = Cyclone Z = Seals	A = Air G = Gas	B = Bypass I = Inlet O = Outlet S = Seal	H = Fly Ash N = No Particulate	D = Dry W = Wet Y = Dry & Wet

Description: PGID = P (Precipitator) G (Gas) I (Inlet) H (Fly Ash) D (Dry)

Expansion joints are installed on the combustion air inlet ducts to the combustion turbine, as well as the ducts on the gas outlet to the HRSG and stack breaching. Penetration seals are installed to seal the HRSG casing to any pipes that are penetrating through the casing.



Installing a Flexi-Duct™ penetration seal

The gas turbines' rapid ramp up of high velocity gas (up to 2 million kg/hr) and its accelerated increase in temperature (up to 650°C) yield specific requirements for Thorburn's expansion joints. These requirements include, absorption of large amounts of axial and lateral movements, flow induced vibration, and thermal shock of metallic components. Therefore, Thorburn's GTEX system should never be looked upon as a commodity.

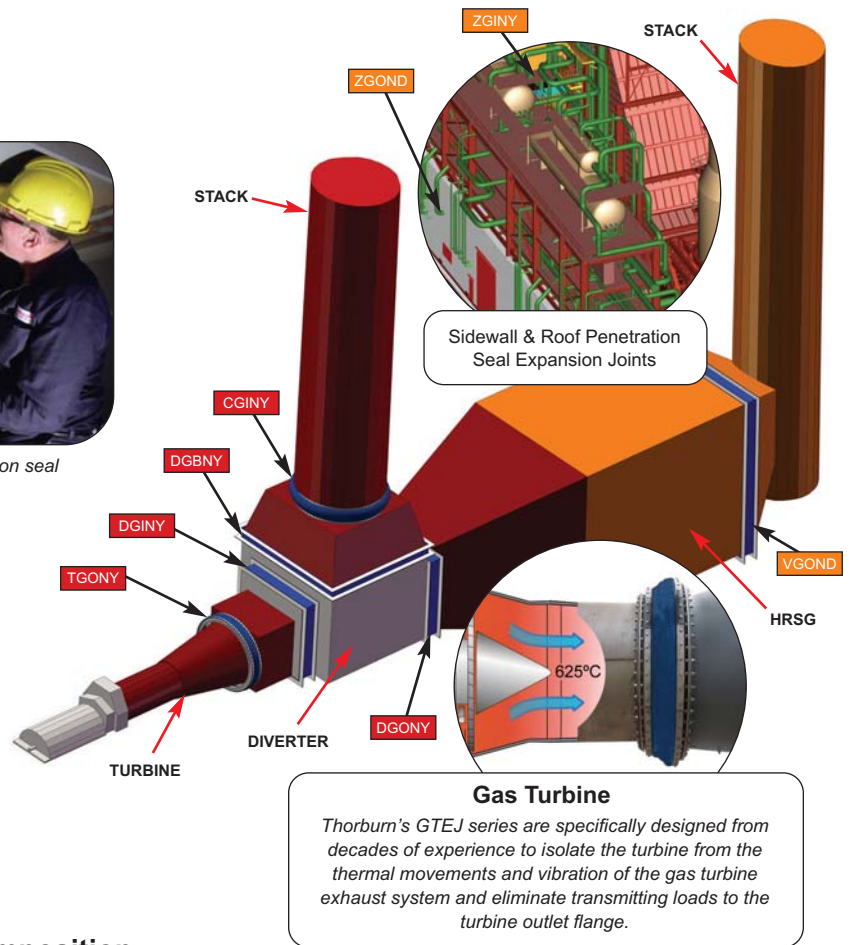

Application Ducting Temperature & Media Composition

- 70°F to 350°F MCOT, distance from turbine reduces gas velocity and temperature. Dry gas, no particles
- 70°F to 1200°F MCOT, high velocity dry flue gas with accelerated temperature during turbine ramp-up. During outage corrosive flue gas present.

Inlet HRSG / Gas Turbine Exhaust Expansion Joints (Cold to Cold Frame)

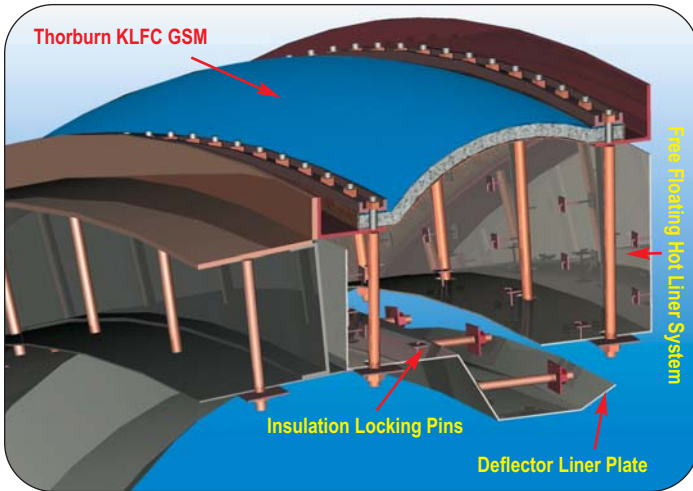

GSM stand alone temperature to 1100°C

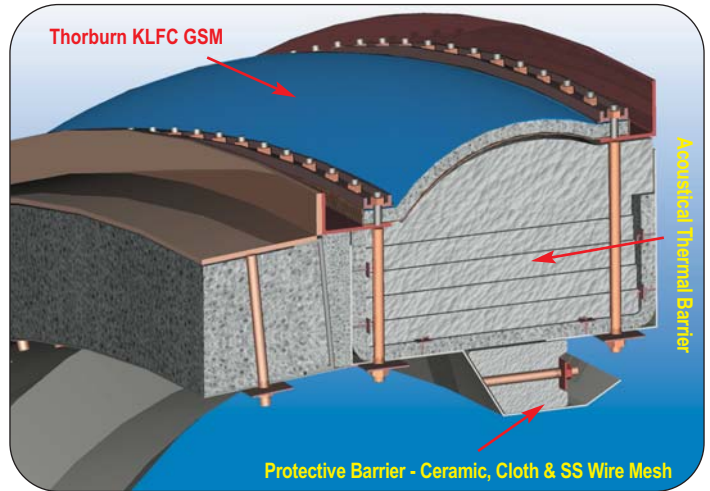

Severe Service Condition Rapid temperature acceleration to 650°C high flow ± pulsation

Thorburn “GTEJ-CC” Cold to Cold Frame Design

- Free floating hot liner system allows positive independent thermal expansion
- Inlet deflector liner plate prevents vortex effect & protects the cavity during turbine washing
- Internal pins lock & secure insulation during operation
- Typical liner material is made from SA240 type 409/410SS

Thorburn “GTEJ-CC” Thermal & Acoustical Barriers

- Thermal insulation barrier reduces the 625°C inner hot face temperature to 60°C on the KLFC (GSM) outer cold face
- The KLFC temperature without added insulation is up to 1100°C
- The acoustical noise reduction barrier reduces the noise level from 134dBA @ 8000 Hz to 66.7 dBA at 1m distance
- The KLFC design is impervious to internal & external corrosion

Gas Turbine Exhaust Expansion Joint Frame Styles (Hot to Hot/Hot to Cold Frame)



Mesh guard protection permits free convection and cooling of the expansion joint

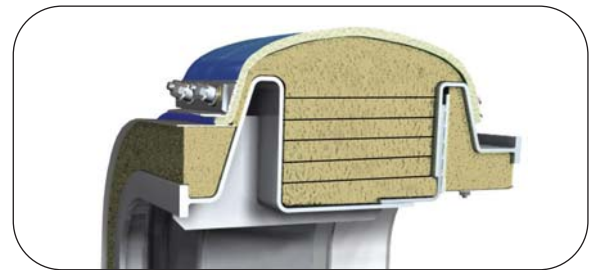

Frame Style GTEJ-HC (Hot to Cold)

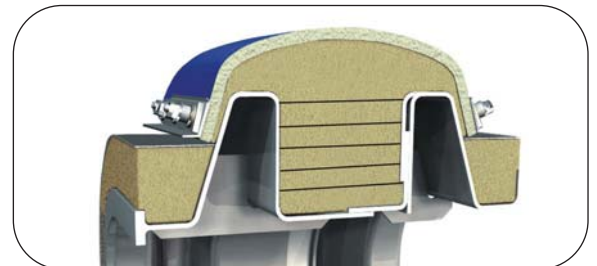

Frame Style GTEJ-HH (Hot to Hot)

Thorburn’s GTEJ frame designs prevent large temperature differentials occurring within the frame and reduce thermal stress on the internal metallic frame components. Thorburn’s GTEJ frame designs have been developed using Finite Element Analysis (FEA) to provide confidence in addressing thermal shock, temperature distribution, mounting methods and bolt up.

Thorburn's Other Flexi-Duct™ HRSG & Bypass Expansion Joints



Thorburn's outlet expansion joint being installed at an HRSG in Huntstown, Ireland

HRSG Outlet to Stack Expansion Joints

The HRSG outlet expansion joint is located at the end of the HRSG near it's stack. The flue gas temperature at the outlet expansion joint is less than 150°C and is no longer the key expansion joint design consideration. Acoustical impedance, due point and condensation corrosion are the principal design considerations. Specifically designed acoustic insulation pillows provide impedance which reduces noise to less than 80dB. Water condensation and corrosion is limited by the liner and drainage system.

Bypass & Diffuser Expansion Joints

A typical bypass system in a gas fired power plant has two expansion joints: one located at the inlet of the bypass and another located at the stack. These expansion joints must withstand 625°C temperature therefore their construction is similar to Thorburn's Turbine Exhaust, Inlet HRSG expansion joints.

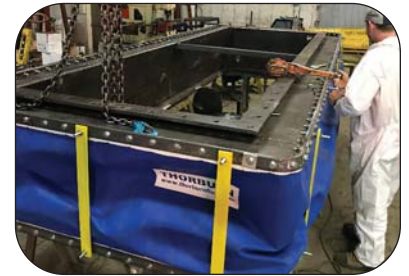

Thorburn's high temperature Flexi-Duct™ bypass expansion joint under construction

Thorburn's Flexi-Duct™ HRSG Penetration Seal Expansion Joints



Six non-insulated steam pipes grouped into one Thorburn Flexi-Duct™ penetration seal expansion joint at a Florida power plant

Thorburn's Flexi-Duct™ penetration seal expansion joints have one end installed on the HRSG casing and the other end directly on to the steam pipes. Thorburn's Flexi-Duct™ penetration seal expansion joints have three purposes, protect nearby personnel and environment, prevent the hot flue gases escaping from the HRSG and absorb thermal & mechanical movements of the steam pipes. Thorburn's Flexi-Duct™ penetration seal expansion joints typically operate in limited space and are installed on a single steam pipe or a group of steam pipes.

Thorburn's Flexi-Duct™ penetration seal expansion joints have specifically designed internal insulation to keep the GSM skin temperature hand touchable. For fabric penetration seals in close proximity to other penetration seal expansion joints, the design temperature should not exceed 325°C. Otherwise Thorburn's Flexi-Duct™ penetration seal expansion joints on a single pipe with full free convection can withstand temperatures up to 625°C.



Thorburn Flexi-Duct™ high temperature 625°C penetration seal expansion joint on a single steam pipe system

Thorburn's Flexi-Duct™ penetration seal expansion joints Advantages

- Easily replaceable on-site
- Can be supplied fully insulated
- Requires very little space compared to metal penetration seals
- Greater lateral & axial movement compared to metal penetration seals



A series of fully insulated dual steam pipes into one Thorburn Flexi-Duct™ penetration seal expansion joint in a Mexican power plant

Thorburn's Flexi-Duct™ Integral Drainage System Solutions



Gas turbine exhaust ductwork sloping downwards to the expansion joint

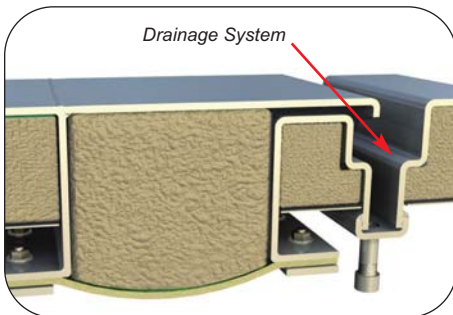

Thorburn's gas turbine expansion joint upstream custom integral drainage system.

Thorburn's gas turbine expansion joints are designed to withstand rapid acceleration of heat, hot gases and thermal movements, but not fluid build up from water washing of the duct work or gas turbine.

Water washing consequences

- A corrosive effect on insulation materials
- Reduction in insulation material strength
- Potential fire hazard

The effect of these consequences could lead to unexpected failure of the expansion joint. Thorburn's engineers can design a custom drainage system upstream from the expansion joint to eliminate washing water damage to the expansion joint.

Thorburn's custom drainage system is typically positioned on the lower portion of the duct where the water would naturally accumulate. Thorburn's drainage system can be equipped with hose assemblies attached to the outside duct to flow into a basin.



Thorburn's gas turbine expansion joint before turbine washing showing packed thermal insulation



Thorburn's gas turbine expansion joint after turbine washing showing compacted insulation creating a cavity

Thorburn's Flexi-Duct™ HRSG & Inlet Expansion Joint Interface Solutions

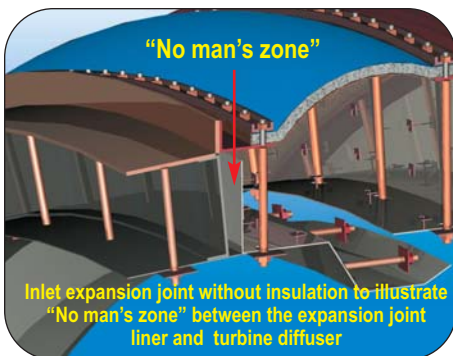

Inlet expansion joint without insulation to illustrate "No man's zone" between the expansion joint liner and turbine diffuser

The HRSG and the gas turbine are installed by two different contractors. The insulation pannels are pre-fabricated with 200mm thick insulation off-site and placed into position on-site separately by the respective contractors. Thorburn's field technicians and engineers have found a problem between the expansion joint's floating liner and the turbine diffuser. Thorburn refers to this area as "No man's zone" because the insulation can be spotty or completely left out because it falls between two contractors scope of supply.



Pre-fabricated insulation pannels at a Dominican Republic HRSG/Gas turbine installation

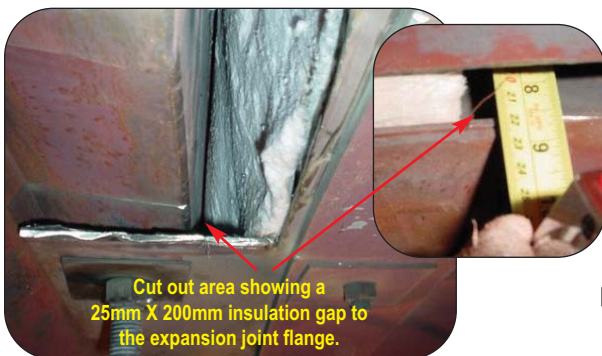

Cut out area showing a 25mm X 200mm insulation gap to the expansion joint flange.

The insulation gap allows the hot (625°C) turbine exhaust gas to have a path to the exterior casing which radiates heat to the expansion joint flange, bolts, backing bars and onto the GSM which eventually leads to GSM burn out and expansion joint failure. Thorburn's field technicians routinely bring this point to the attention of the contractors and clients representatives to make sure the contractors properly insulate this area.

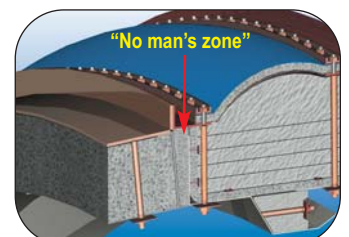

Adding insulation into "No man's zone" reduced the temperature at a Singapore gas turbine HRSG installation from 325°C to 110°C.

Flexi-Duct™ Pulverized Coal Power Plant Expansion Joint Applications



Thorburn's Flexi-Duct™ expansion joints were installed in all the processes at the Tanjung Bin power plant in Malaysia.

Expansion Joint Application

P G I H D				
Equipment	Media	Location	Particulate	Wet/Dry
A = Air Heater B = Boiler C = Chimney/Stack D = Diverter E = Economizer F = Forced Draft Fan G = Gas Recirculation Fan H = Heater I = Induced Draft Fan P = Precipitator M = Coal Mill S = Scrubber T = Turbine U = Main Fan V = HRSG X = Turbo Expander Y = Cyclone	A = Air G = Gas	B = Bypass I = Inlet O = Outlet S = Seal	H = Fly Ash N = No Particulate	D = Dry W = Wet Y = Dry & Wet

Description: PGID = P (Precipitator) G (Gas) I (Inlet) H (Fly Ash) D (Dry)

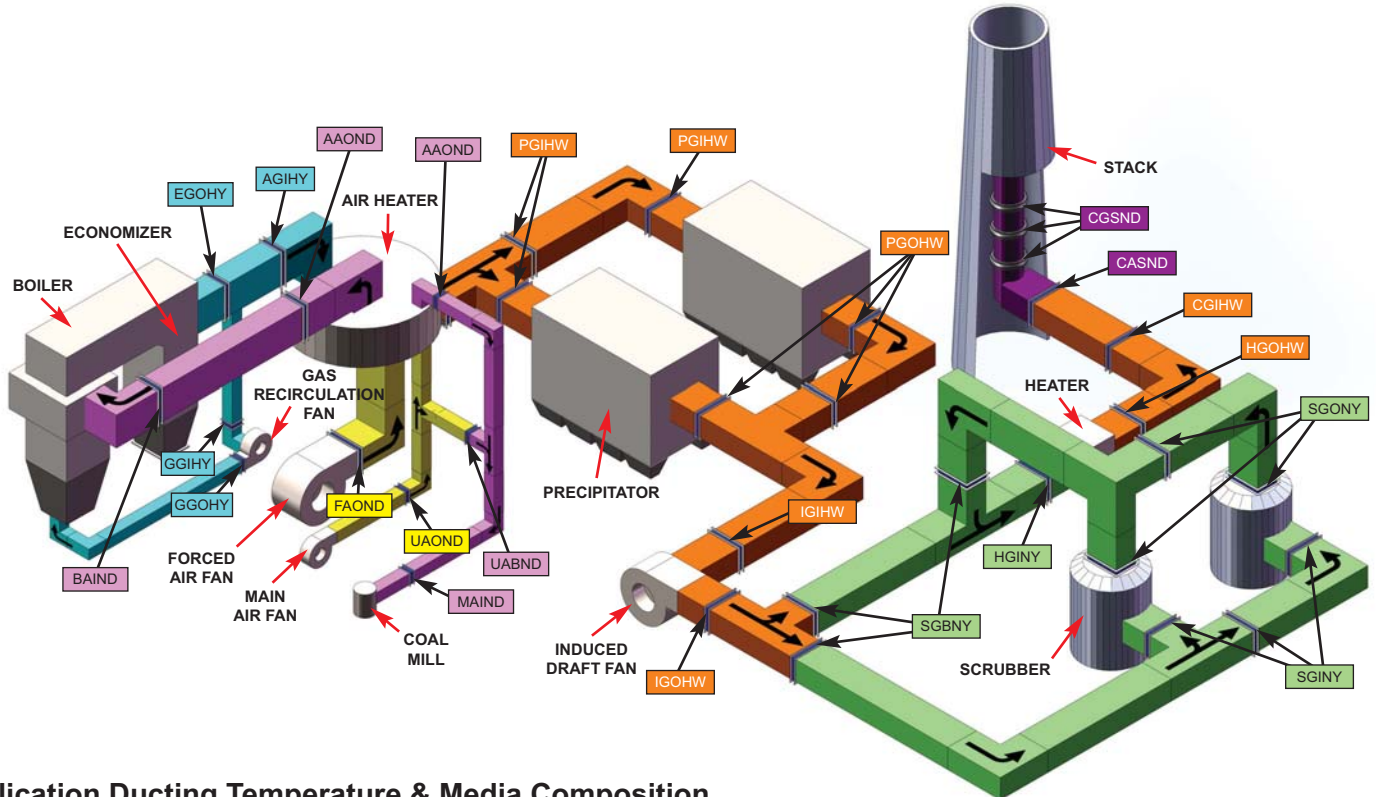

Application Ducting Temperature & Media Composition

- 500°F to 1200°F MCOT, low pH flue gas, dry when operating, wet when cycling creating corrosive condensates, heavy fly ash particulate.
- 400°F to 750°F MCOT, dry clean ambient air, no particulates.
- - 20°F to 120°F MCOT, dry clean ambient air, no particulates.
- 350°F to 500°F MCOT, wet flue gas & scrubbed flue gas, minor particulates present, frequent outages will yield wet corrosive conditions.
- 150°F to 350°F MCOT, dry flue gas (inlet) to scrubber, wet flue gas at scrubber inlet and outlet, no particulates.
- - 20°F to 350°F MCOT, dry clean flue gas or ambient air, no particulates

Flexi-Duct™ Suggested Expansion Joints for Pulverized Coal Applications

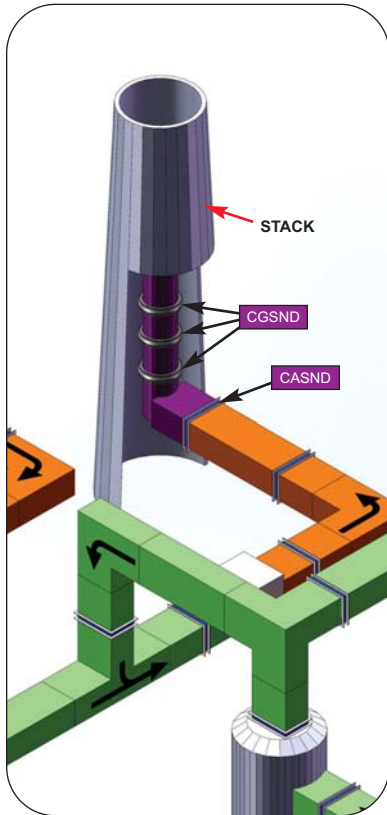

Thorburn's penetration seal and stack seal expansion joints

Thorburn's Stack Air Seal Expansion Joints (CASND)

Thorburn's K12 or M12 GSM is installed to span between two metallic frames to make a seal. This prevents the flue gas ducts from penetrating through the chimney liner and the outer shell. Leaky seals will allow the flue gasses to enter the chimney annulus and attack the outer concrete structural shell.

Advantages

- Gas tight seal when installed with Thorburn's JSGT PTFE gasket tape seals
- Easily repairable with heat sealing methods on site

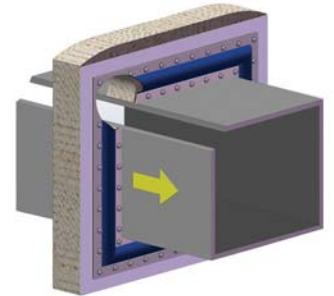

Thorburn's penetration air seal stack expansion joints are easily accessible for inspection or repair

Thorburn's Gas Seal Stack Expansion Joints (CGSND)

Thorburn's K12 or M12 GSM replaces traditional rope packing seals between the adjacent sections of the chimney brick liners. This improvement provides a better seal that resists the process gasses and prevents attack and chimney deterioration.

- Unique frame design for easy access
- Heat sealing reparability
- Corrosive resistant GSM for longer sealing life

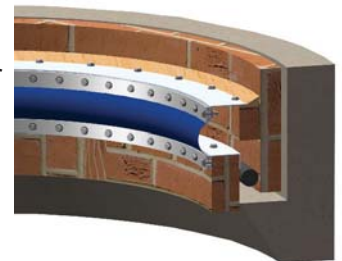

Thorburn's gas seal stack expansion joints provides better sealing and improved inspection and maintenance

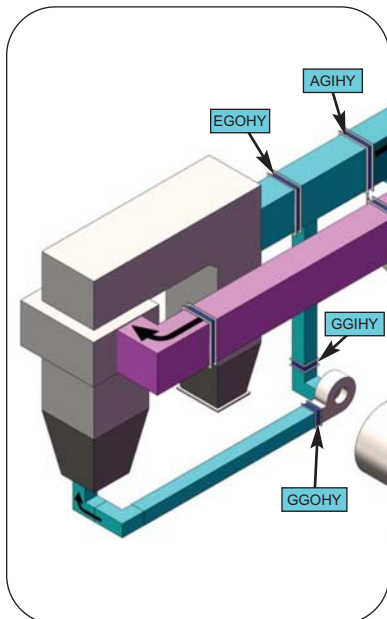

Thorburn's hot primary inlet/outlet flue duct expansion joints

Thorburn's Flexi-Duct™ Inlet/Outlet Expansion Joints

When the combustion flue gas streams are rich with fines (sand-like particles) and the expansion joint liner system is installed with a gap, the fines enter into the expansion joint cavity preventing movement and causing combustion or an explosion inside the expansion joint cavity. The problem is amplified when the expansion joint is required to absorb large amounts of lateral and axial movement which will transfer stress onto the adjoining equipment or ducting system.

Thorburn's Flexi-Duct expansion joint with its proprietary Zero-Gap Floating Liner Series "ZP", complete with accumulation pillow, provides the solution to this problematic application. Thorburn's Zero-Gap unique "floating liner" keeps the telescopic liners touching each other eliminating the gap created by an offset while allowing for large amounts of axial and lateral deflection.

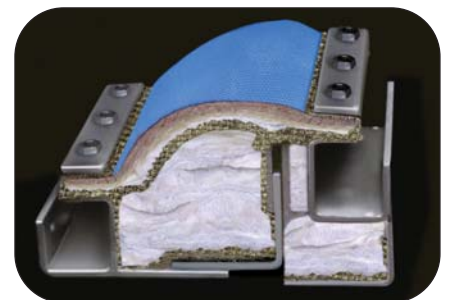

Thorburn's Zero Gap Floating Liner Series "ZP" with KLF or KLFC GSM depending on application

- Ideally suited when large amounts of particles are suspended in the gas flow
- Absorbs axial & lateral deflection while maintaining a zero gap between the liners
- Provides protection against expansion joint cavity explosion

Flexi-Duct™ CFB Plant Expansion Joint Applications



Power Plant using Circulating Fluidized Bed (CFB) process has the ability to achieve lower emission of pollutants. Typical CFB fuel source is coal but other fuels can be used. Thorburn's Flexi-Duct™ expansion joints were chosen by Foster Wheeler for the Turow (Poland) CFB

Expansion Joint Application

P G I H D				
Equipment	Media	Location	Particulate	Wet/Dry
A = Air Heater B = Boiler C = Chimney/Stack D = Diverter E = Economizer F = Forced Draft Fan G = Gas Recirculation Fan H = Heater I = Induced Draft Fan P = Precipitator M = Coal Mill S = Scrubber T = Turbine U = Main Fan V = HRSG X = Turbo Expander Y = Cyclone	A = Air G = Gas	B = Bypass I = Inlet O = Outlet S = Seal	H = Fly Ash N = No Particulate	D = Dry W = Wet Y = Dry & Wet

Description: PGID = P (Precipitator) G (Gas) I (Inlet) H (Fly Ash) D (Dry)

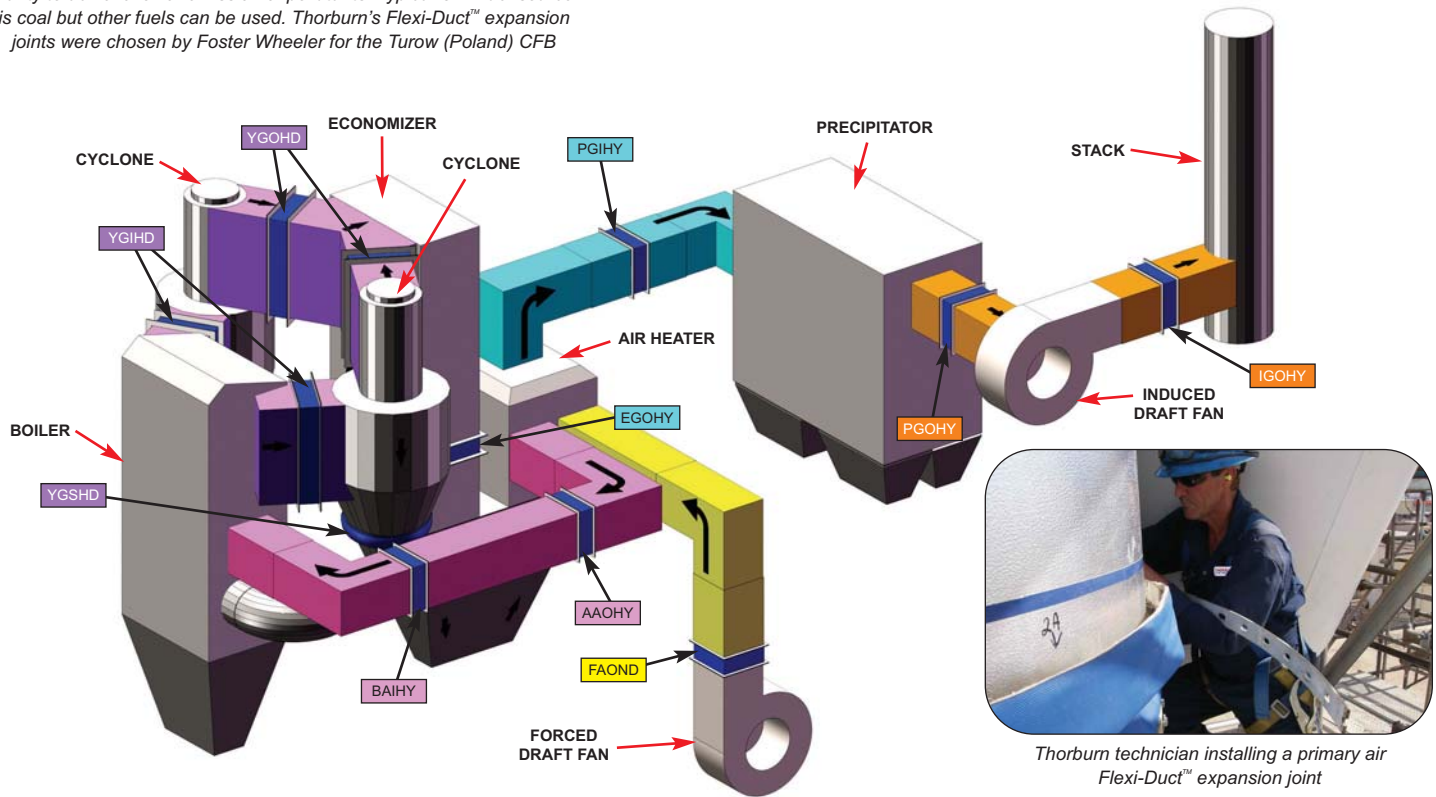

Thorburn technician installing a primary air Flexi-Duct™ expansion joint

Application Ducting Temperature & Media Composition

- 700°F to 1200°F MCOT, low pH flue gas, dry when operating, wet when cycling creating corrosive condensates, heavy fly ash particulate.
- 600°F to 750°F MCOT, dry clean ambient air, no particulates.
- - 20°F to 120°F MCOT, dry clean ambient air, no particulates.
- 350°F to 500°F MCOT, wet flue gas & scrubbed flue gas, minor particulates present, frequent outages will yield wet corrosive conditions.
- Up to 2000°F MCOT, dry flue gas, abrasive rich in "fines" (sand like particles), extremely abrasive, heavy fly ash.

Flexi-Duct™ Suggested Expansion Joints for CFB Applications

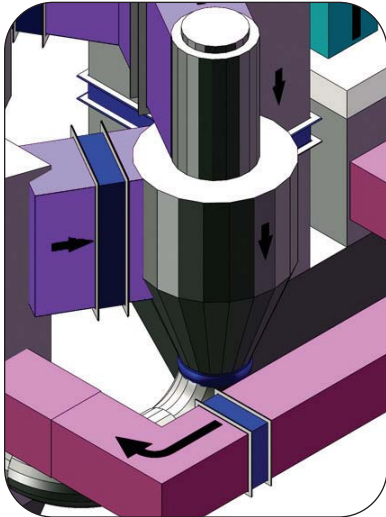

The efficiency of the CFB combustion process is dependant on the recycling of fines (unburnt fuel in a sand-like mix) back to the combuster. Refractory lined hot cyclones are used to separate these fines from the flue gas stream. A high temperature (exceeding 900°C) flue gas suspended with heavy, dense, abrasive particles is conveyed through a refractory lined duct called a "Loop Seal" to the combuster.

Flexi-Duct™ Loop Seal Expansion Joints Zero-Gap Refractory Floating Liner System

Thorburn's loop seal expansion joint is specifically designed for this challenging CFB application which must satisfy a design temperature of 1100°C, 200mm of axial movement, 80mm of lateral deflection, transferring flue gas laden with fly ash and combustion. At the core of the design is a refractory zero-gap floating liner system with no exposed metal components, a tertiary sealing system plus a pressurized cavity for ash purging. Thorburn's loop seal expansion joint is rebuildable for ease of maintenance.

Flexi-Duct™ Zero-Gap liner system with no exposed metallic components

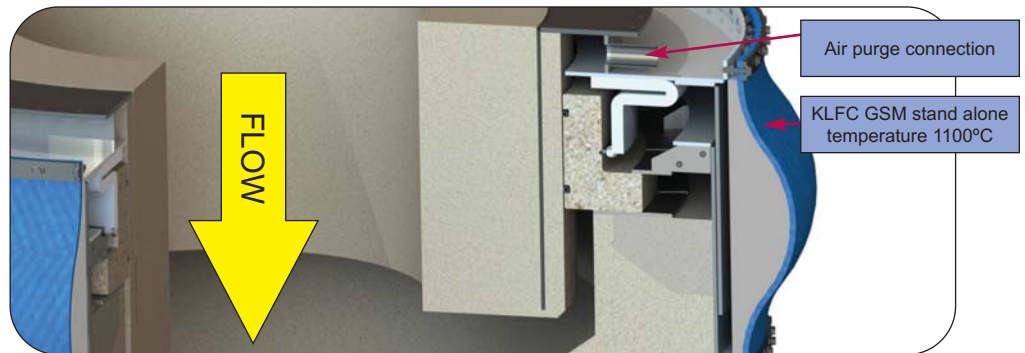

Thorburn's Flexi-Duct™ expansion joints are used to eliminate transfer loads to the cyclone structure. Failure of this critical expansion joint would result in loss fines to the atmosphere, combuster pressure loss and mechanical loads to the cyclone structure which could result in a plant shutdown

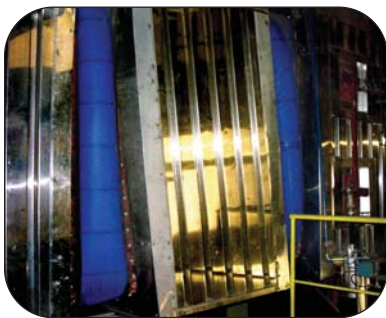

Thorburn's windbox expansion joints installed at the Turow CFB Power Station in Poland

Flexi-Duct™ Windbox Expansion Joints

Thorburn's Windbox expansion joints incorporates the zero-gap liner system to absorb mechanical movement caused by the transport of high velocity primary and secondary airflow. Thorburn's Windbox expansion joints address the problems of high speed airflow saturated with fines which generate high pressure zones and turbulent fluctuations.

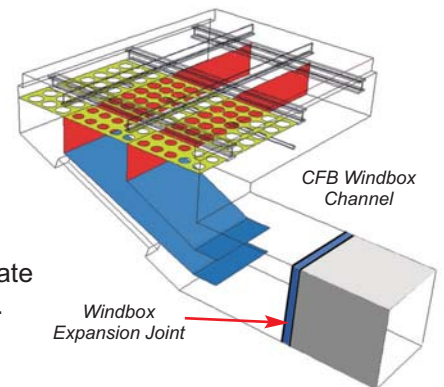

Flexi-Duct™ Barrel Hoop Expansion Joints

Thorburn's Barrel Hoop Technology supports large diameter expansion joints during upset duct movement and high pressure conditions. Barrel Hoop expansion joints also prevent GSM splice detachment under high stress conditions.



Thorburn's Barrel Hoop expansion joints installed on the primary air lines at the JEA CFB Power Station in Florida

Flexi-Duct™ Pantograph Expansion Joints

Thorburn manufactures its Flexi-Duct™ with pantograph support systems to reduce the harmful effects of folds on the GSM in high temperature applications. Folds prevent free convection and can result in GSM failure.



Thorburn's Flexi-Duct™ tertiary expansion joint with a pantograph support system to eliminate hotspot and absorb 600mm (24") lateral and 50mm (2") axial deflection

Flexi-Duct™ Quick-Clamp Clamping System



Thorburn supplied over 100 Flexi-Duct™ round expansion joints with its proprietary clamping system for the Vale clean AER project in Sudbury Canada



Flexi-Duct™ expansion joints with Thorburn's Quick-Clamp system



Thorburn supplied over 100 Flexi-Duct™ rectangular expansion joints with traditional flat bar/bolting attachment method for the Vale clean AER project in Sudbury Canada

Thorburn's Flexi-Duct™ Quick-Clamp System

The traditional method to secure a GSM to a round expansion joint frame is to use backing bars with slotted holes at 100mm centers. When bolted up this attachment method provides the required compression force on the GSM to make a seal. Thorburn's Quick-Clamp system is an alternative method (for round expansion joints only) by using a clamping system to attach the GSM to the expansion joint frame and make a seal. The compression force on the GSM is accomplished through two semicircle round bars which are placed in the channel over the GSM and then joined in two locations. Thorburn's Quick-Clamp provides a 360° uniform compression force that secures and seals the GSM to the expansion joint frame.

Thorburn's Quick-Clamp Advantages

- **Fast connection & disconnection of GSM**
Quick and easy method for GSM replacement.
- **Provides a 360° uniform compression force**
When combined with a gasket it provides the better seal
- **Simple assembly & disassembly** (two connection points)
Provides a quick method of cleaning the expansion joint cavity

Thorburn's Flexi-Duct™ Quick-Clamp System

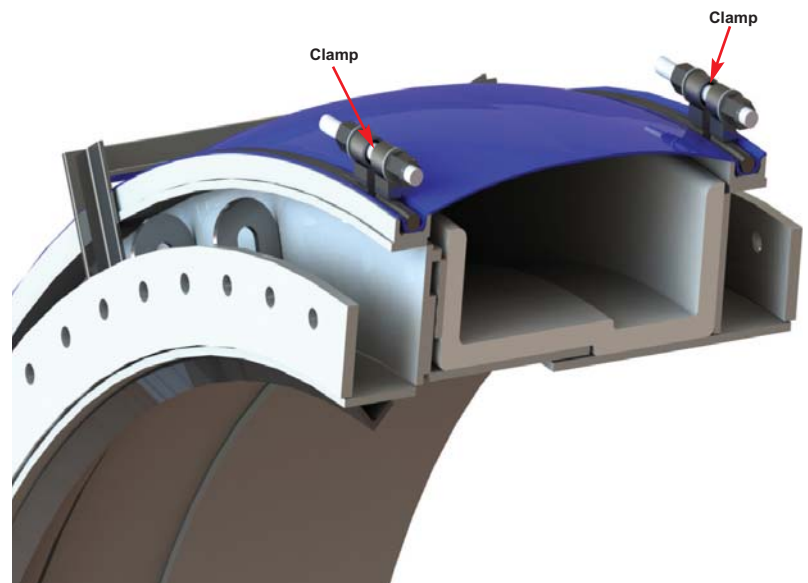

Thorburn's Quick-Clamp System on a Flexi-Duct™ Expansion Joint with Zero Gap Liners

Flexi-Duct™ Suggested Expansion Joints for Aluminum Applications



Alcoa aluminum smelter located in Baie-Comeau, Canada chose Thorburn's Flexi-Duct™ expansion joints for its potroom off-gas ducting system

Flexi-Duct™ Potroom Off-Gas Expansion Joints

Thorburn Flexi-Duct™ expansion joint technology provides a superior choice for aluminum gas treatment ducting applications. The Alcoa aluminum smelter located in Baie-Comeau, Quebec, chose Thorburn's Flexi-Duct™ expansion joints to absorb thermal expansion of ducts handling off-gasses coming from the pots (in the potroom) while avoiding infiltrations in the duct systems. The aluminum potroom off-gas ducting system to the scrubber has a high concentration of corrosive hydrogen fluoride (hydrofluoric acid) which is one of the most challenging applications in an aluminum smelter. Thorburn's K12 GSM with its TLFP corrosion barrier is chemically inert to the highly corrosive hydrogen fluoride (hydrofluoric acid) off-gasses.



Aluminum smelter potroom off-gas ducting system with Thorburn Flexi-Duct™ expansion joints installed

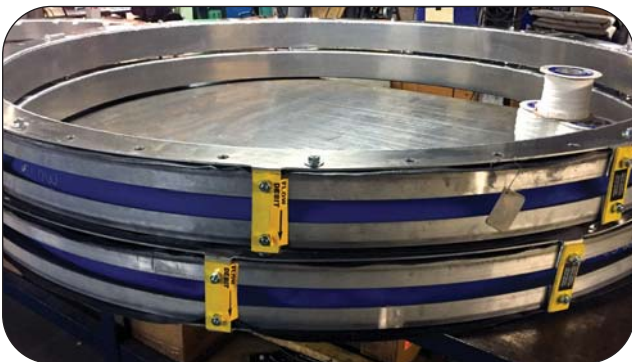

Thorburn's Flexi-Duct™ expansion joints manufactured with Aluminum 6061-T6 (SB-209) frames & backing bars to resist corrosion and reduce weight on the aluminum ducting system

Thorburn's Flexi-Duct™ expansion joints installed at Alcoa included a K12 GSM, JSGT PTFE Gasket Tape, UBB Frame style (with angle flange backing bars) and a BL integral bolt-in liner system. All metal components were made from Aluminum 6061-T6 (SB-209).

Thorburn's TLFP 20/40/60 Flexi-Duct™ Duct Connectors

Thorburn's TLFP 20/40/60 provides a non-flammable dielectric connector and a formidable corrosion barrier for fume collection systems on the pot lines and scrubber systems. Thorburn's TLFP consists solely of PTFE resins and is therefore chemically inert and completely unaffected by hydrofluoric gases making it an ideal gas seal membrane in a Aluminum Potline and Scrubber Ducting System.

Advantages

- Sizes 25mm to 760mm
- Pressure ± 1270mm H₂O
- -73°C to +315°C



Thorburn's TLFP expansion joints & connectors can be manufactured with flanged or cuffed ends. The reinforcing rings can be made from encapsulated solid PTFE or 316SS



Thorburn's certified welder welding an aluminum 6061-T6 (SB-209) Flexi-Duct™ frame with ER 4043 AISI5 filler metal using Thorburn's certified ASME Section IX procedures

Flexi-Duct™ Bootflex™ Expansion Joints

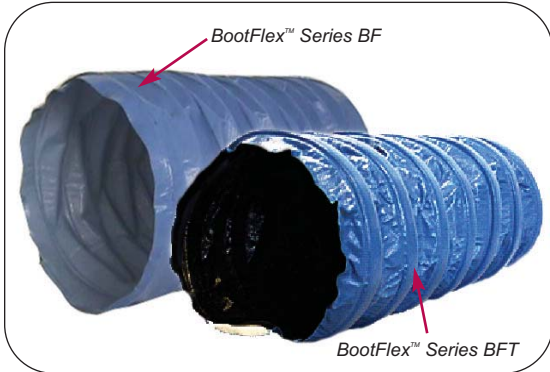

BootFlex™ Series BF with helical steel wire encapsulated between 2 TLFP films (left) & Series BFT with PTFE annular support rings encapsulated between 2 TLFP films (right)



BootFlex™ remains round under a tight bend radius of 1X ID



Thorburn's BootFlex™ is available with integral cuff ends with clamps & flanged ends with custom bolting and backing bars

Thorburn's BootFlex™ Series BF & BFT

are strong laminated seals that encapsulate a rugged helical, high tensile stainless steel spring coil (Series BF) or solid PTFE annular support rings (Series BFT). Thorburn's Bootflex™ is chemically inert (except molten alkali metals and organic halogenated compounds) and can be used on any wet or dry ducting application. Thorburn's Bootflex™ Series BFT can be used in chlorine applications where permeation of chlorine molecules often corrode the metallic support coils of inferior flexible ducting hoses.

Thorburn's high quality Bootflex™ is accepted as meeting Factory Mutual Test 4910 for evaluating flame, smoke and corrosion parameters of clean room materials.

Thorburn's BootFlex™ Features

- Chemically Inert & Corrosion Free
- Zero porosity, lower permeation than coated products
- Superior thermal stability and mechanical strength
- Stand alone temperature of -73°C to 316°C.
- Large amounts of axial and lateral movements 6:1 compression ratio
- Pressure ± 1300mm (50") H₂O
- Non-Flammable (as per Factory Mutual Test 4910) & ideal for applications with fire rating requirements
- Sizes range from 25mm (1") to 760mm (30")
- Unaffected by UV exposure & will not grow fungus

Applications

- Clean rooms
- Fume exhausting & control
- Pollution abatement
- Chemical & fossil fuel plants



Thorburn Flexi-Duct™ BootFlex™ on a fume exhaust duct at a sulphuric acid plant

Technical Specification

Overall Weight: 984 g/m²

Thickness: 0.51mm

Tensile Strength: 778N/50mm

Tear Strength: 295N/50mm

MCOT: 316°C

GSM: 2 Ply TLFP

Helical Wire: High Tensile 316SS (also available in other alloys)

Annular Support Rings: PTFE

How to Order Thorburn's BootFlex™

BF-8-FL-RS6-CF-CS6-48

Example Description:

Bootflex™ Series BF (Type) - **8** (ID Size) - **FL** (1st end Flanged) - **BS6** (Backing Bars made of 316SS) - **CF** (2nd end Cuff) - **CS6** (Clamp made of 316SS) - **48** (Length in inches)

Bootflex ID: Code 1= 1"/DIN25 Code 1.5= 1.5"/DIN40 Code 2= 2"/DIN50 Code 3= 3"/DIN80...

Code 10= 10"/DIN250 Code 12= 12"/DIN300 Code 30= 30"/DIN750

End Style Codes: FL = Flange (Specify bolt pattern ie: #150, #PN10) CF = Cuff (Specify length) PL = Plain end

Attachment Codes: B = Backing Bar C = Clamp **Material Code:** S6 = 316SS (other material available)

Thorburn's Flexi-Duct™ Bootflex™ Series TCT Expansion Joints



Typical Thorburn BootFlex™ TCT cylinder rod cover system

Protective Bellows Covers

Thorburn's BootFlex™ Series TCT is an ideal cover for cylinder rods and rolled ball screws that is airtight, resistant to oil, sand and metal chips. An excellent design feature of Thorburn's BootFlex™ is the inside diameter increases rather than decreases as the cover is extended. Also available as sewn bellows in round, oval and rectangular shapes.

Applications

- Protect components from abrasion & liquids
- Flexible dust seal between two joints
- Protection against dust and light particles



Bolted flanged end BootFlex™ TCT connector

How to Order Thorburn Model TCT Expansion Joints

Specify Closed Length (CL) & Open Length (OL)

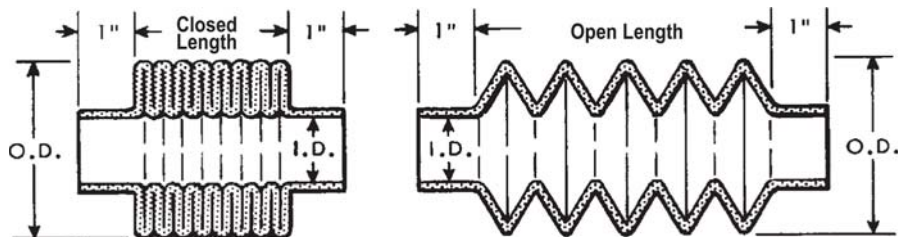

Collar end BootFlex™ TCT connector

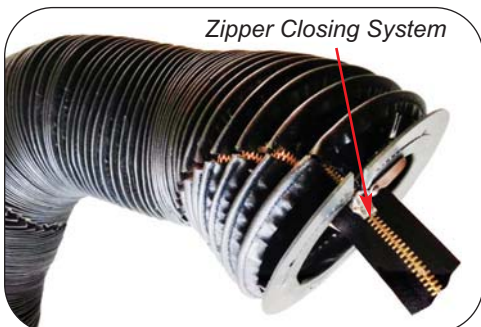

Zipper Closing System

6" DIN150 Clamshell type, flanged end, BootFlex™ TCT connector with zipper closing system. 5,000mm length compresses to 350mm (93% Compression)

Material Ordering Codes		
Elastomer Type	Thorburn Code	MCOT
Neoprene	C	100°C (212°F)
Silicone	L	260°C (500°F)
Butyl	E	149°C (300°F)
Viton	I	204°C (400°F)
Nitrile	D	113°C (235°F)
PVC	P	49°C (120°F)
EPDM	H	149°C (300°F)
PTFE	J	260°C (500°F)

End & Accessory Ordering Codes	
End Type	Code & Specs
Flange	1
Inside Flange	2
Collar	3
Flange Collar	4
Accessories*	Thorburn Code
Back Flange Ring	R
Clamps	C
Zipper Clamshell	Z

* No Accessory - Leave Blank

TCT-6-4X-3Y-C-Z-CL350mm-OL5000mm

Example Description:

Bootflex™ TCT - 6 (DIN150 - 6 "ID) - **4** (1st End Type - Flanged X= Specify Flange ID, OD, Bolt Circle) - **3** (2nd End Type - Collar Y= Specify Collar ID, Collar Length) - **C** (Material - Neoprene) - **Z** (Accessory - Zipper Clamshell) - **CL** (Closed Length 350mm (14")) - **OL** (Closed Length 5,000mm (200"))

Bootflex™ ID: Code 1= 1"/DIN25 Code 1.5= 1.5"/DIN40 Code 2= 2"/DIN50 Code 3= 3"/DIN80... Code 10= 10"/DIN250 Code 12= 12"/DIN300 Code 24= 24"/DIN600

Accessories - Heat Sealing Films

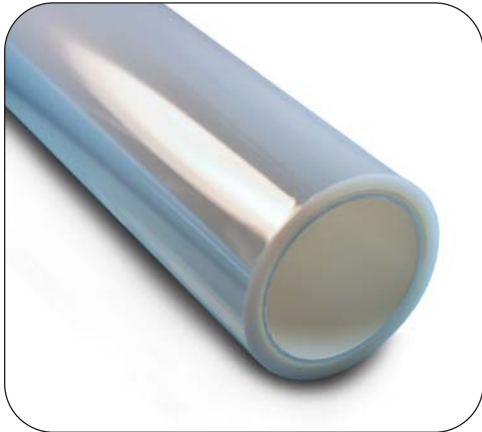

Thorburn PFA splicing film

Perfluoroalcoxy (PFA) Splicing Film

Thorburn PFA films are produced from Perfluoroalcoxy (PFA) resin by a melt extrusion casting process. PFA films offer all the benefits of fully fluorinated films, such as a high continuous use temperature of 500°F (260°C), high chemical and stress crack resistance, and superior dielectric performance.

- PFA films can be heat-sealed, thermoformed, laminated to various substrates, and used as an excellent hot-melt adhesive.
- PFA film is chemically inert and resistant to virtually all chemicals. It is best suited for applications where the combination of high temperature resistance and high chemical resistance is required, such as chemical pumps, tank linings, shrink roll covers, rupture discs and gaskets.
- PFA films possess excellent dielectric properties over a widest temperature range, which make them invaluable in circuit board laminates and wire & cable insulation applications.

PFA Film Grades

PFA PG (Premium Grade)

- Manufactured out of 100% virgin premium grade PFA resin with MFI range of 1.5-2.5
- PFA PG is a grade of choice for dielectric applications and where visual perfection and clarity are required

PFA SG (Splicing Grade)

- Possesses all physical, mechanical, and thermal properties of the Premium Grade PFA film
- Perfect solution for heat sealing, welding, and other melt adhesive applications that don't have high visual perfection and clarity requirements

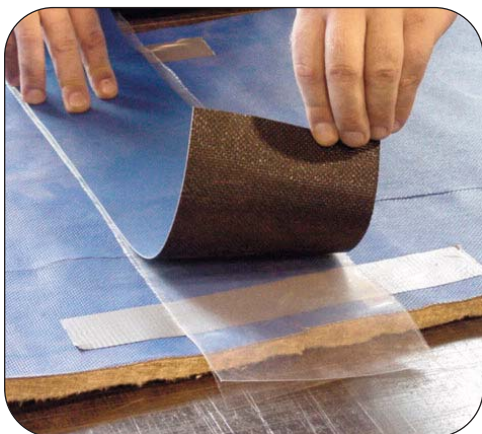

Placing flexible belt repair patch over PFA splicing film

PFA Film Specifications

- Thickness range from 0.0005" to 0.010" (12 to 250 μm)
- Standard width: up to 60" (1,524 mm)
- Thicknesses >0.002": up to 62" (1,575 mm)
- Any slit widths available upon request
- Bondable (plasma treated or chemically etched) surfaces available

PFA Film Characteristics

- Best high & low temperature resistance among melt process fluoropolymers
- Continuous service temperature range from -425 to 500°F (-254 to 260°C)
- Melt temperature range: 572 to 590°F (300 to 310°C)
- Chemically inert and solvent resistant to virtually all chemicals
- Outstanding dielectric properties over a wide range of frequencies and temperatures.
- High dielectric strength, over 6,500 V/mil for 1-mil film (260 kV/mm for 25 micron film)
- Excellent light transmission and clarity
- Free of plasticizers, processing aids, or additives



Heating iron in operation on PFA splicing film

Accessories - Heat Sealing Films

General Properties	Units	Test Method	PFA PG Film	PFA SG Film
Specific Gravity		ASTM D792		2.15
Area Yield	ft ² /lb/mil			90
Flammability		UL-94		V-0
Water Absorption	%			<0.01
Mechanical Properties				
Tensile Strength	psi (MPa)	ASTM D882		2,500 (17)
Elongation at Break	%	ASTM D882		300
Tensile Modulus	psi (MPa)	ASTM D882		70,000 (480)
Initial Tear Strength (2 mil film)	g	ASTM D1004		500
Propagation Tear Strength (2 mil film)	g	ASTM D1922		75
Folding Endurance (MIT)	cycles, min.	ASTM D2176		100,000
Thermal Properties				
Continuous Use Temperature	°F (°C)	UL-746 B		500 (260)
Melt Point	°F (°C)	ASTM D3418		575 - 590 (302 - 310)
Coeff. of Lin. Thermal Expansion	in/(in °F) (mm/(mm°C))	ASTM D696		5.5X10 ⁻⁵ (9.9X10 ⁻⁵)
Electrical Properties				
Dielectric Strength (1mil film)	volts / mil	ASTM D149	6,500 (260)	n/a
Dielectric Constant 1kHz		ASTM D150	2.0	n/a
Dissipation Factor, 1kHz		ASTM D150	0.0002 - 0.0007	n/a
Optical Properties				
Refractive Index		ASTM D542	1.35	n/a
Solar Transmission	%	ASTM E424	96	n/a
Product Offering				
Width	inches (mm)		0.5 - 2 mil: up to 60" (1,524); 3 - 10mil: up to 62" (1,575)	
Thickness	mils (µm)		0.5 - 10 (12.5 - 250)	
Standard Colors			Clear	Clear Tinted
Surface Treatments Available				
Chemical Etching			•	•
Plasma Treatment			•	•
Applications, Markets				
Composite Molding Process: Release Films				
Chemical Process / Equipment			•	•
Heat Sealing / Welding / Melt Adhesive				•
Electrical / Electronics			•	
Medical			•	
Optical /Photovoltaics			•	
Protective/Decorative			•	

Accessories - Thorburn Flex Standard Heat Sealing Kit



(Complete Kit Part Number: THSK-6I)

Electric heating iron 3"x6" (76mm X 152mm), 120V, single phase

The heat sealing iron must reach an operating temperature of 725°F (385°C) before attempting to splice. To be placed in the center of the splice applying pressure for a period of 4 minutes. It is important that the heat sealing iron be stationary during heat sealing.



Chilling Block

To be placed over the spliced hot area for 1 minute, which acts as a heat sink and smoother for the spliced surface.



Stainless Steel Backing Plate

1/8" (3mm) thick x 8" (203mm) wide and length equal with the flexible belt to be spliced to act as a heat sink preventing a solid splice adhesion.



Iron Pad

Made of KLF-12 flexible belt, high temperature cloth and stainless steel wire mesh to act as a solid base that is placed directly under the area of the flexible belt to be spliced.



Flexible belt

Thorburn K-12 flexible belt material 6" x 10' (152mm x 3.1m) for repair patching. Cut a sufficient length of GSM for splicing material to cover splice seam. Using a clean rag and acetone, clean both sides of the splicing material then place flexible belt splicing material over seam and centered over the PFA splicing film.



Splicing Material

Splicing PFA Film 6" x 10' (152mm x 3.1m) for repair patching. To be placed between the overlapping ends of the flexible belt GSM. The PFA film should exceed 1/8" on each side the width of the overlapping flexible belt GSM ends.

*For splicing instructions please contact Thorburn Flex

Accessories - Heat Sealing Equipment



Splicing iron 3"x6", 120V, single phase is our standard model, used reliably with expansion joint materials for over 20 years. Standard Sealers feature both a temperature indicator and "On" and "Ready" lights. The Standard 3x6 Heat Sealer is a cost-effective, reusable sealer in a compact, easy-to-manuever design.

Thorburn Flex Part Number: HSI-3X6-120V

Platen Dimension:	3" x 6" (76 x 152mm)
Supply Voltage:	120 V or 240 V
Current:	7.1 A @ 120 V 3-1/2 A @ 240 V
Controller:	RKC SA200
Weight:	22 lbs (10 kg)
Wattage:	850 Watts
Frequency:	60/50 Hz



Splicing iron 3" x 15", 120V, single phase 3x15 Heat Sealer has been used reliably with expansion joint materials for over 20 years. Standard Sealers feature both a temperature indicator and On and Ready lights. Featuring a larger platen, the 3x15 Heat Sealer allows for greater surface coverage in less time than more compact models. The Standard 3x15 Heat Sealer is a cost-effective, reusable sealer in an easy-to-use, two piece design.

Thorburn Flex Part Number: HSI-3X15-120V

Platen Dimension:	3" x 15" (76 x 381mm)
Supply Voltage:	120 V or 240 V
Current:	7.1 A @ 120 V 3.5 A @ 240 V
Controller:	Fenwal Series 54-4
Weight:	22 lbs (10 kg)
Wattage:	900 Watts
Frequency:	60/50 Hz



Splicing iron 3" x 6", 120V, single phase 3x6 Economy Heat Sealer was created for basic heat sealing service with a simple and efficient one piece design. The Economy Sealer features a green On light to indicate that the unit is on, and an amber Ready light which illuminates when the device has reached the correct temperature of 700°F (371°C). The Economy Sealer does not include a temperature display.

Thorburn Flex Part Number: HSIE-3X6-120V

Platen Dimension:	3" x 6" (76 x 152mm)
Supply Voltage:	120 V or 240 V
Current:	3.75 @ 120 V
Controller:	Thermoswitch
Weight:	22 lbs (10 kg)
Wattage:	850 Watts
Frequency:	60/50 Hz



Splicing iron 5" x 8", 120V, single phase 5x8 Clamp Heat Sealer is ideal for applications in which both sides of the material can be accessed. By applying heat to both sides of the material, the time required to make a heat seal is reduced significantly. The 5x8 Clamp Sealer offers both a temperature indicator and On and Ready lights for ease of use.

Thorburn Flex Part Number: HSIC-5X6-120V

Platen Dimension:	5" x 8" (127 x 203mm)
Supply Voltage:	120 V or 240 V
Current:	7.5 A @ 120 V 3.75 A @ 240 V
Controller:	Thermoswitch
Weight:	32 lbs (14.5 kg)
Wattage:	800 Watts
Frequency:	60/50 Hz



Thermal Expansion Chart

Temperature °C	Temperature °F	Carbon Steel	Austenitic Stainless Steel	12CR/17CR/27CR	25CR/20NI
-73°C	-100°F	-1.15	-1.75	-0.98	-1.39
-59°C	-75°F	-1.00	-1.50	-0.85	-1.18
-46°C	-50°F	-0.84	-1.24	-0.72	-0.98
-32°C	-25°F	-0.88	-0.98	-0.57	-0.78
-18°C	0°F	-0.49	-0.72	-0.42	-0.57
-4°C	25°F	-0.32	-0.46	-0.27	-0.37
10°C	50°F	-0.14	-0.21	-0.12	-0.16
21°C	75°F	0.00	0.00	0.00	0.00
38°C	100°F	0.23	0.34	0.20	0.28
52°C	125°F	0.42	0.62	0.36	0.51
66°C	150°F	0.61	0.90	0.53	0.74
79°C	175°F	0.80	1.18	0.69	0.98
93°C	200°F	0.99	1.46	0.86	1.21
107°C	225°F	1.21	1.75	1.03	1.46
121°C	250°F	1.40	2.03	1.21	1.70
135°C	275°F	1.61	2.32	1.36	1.94
149°C	300°F	1.82	2.61	1.56	2.18
163°C	325°F	2.04	2.90	1.74	2.43
177°C	350°F	2.26	3.20	1.93	2.69
190°C	375°F	2.46	3.50	2.11	2.94
204°C	400°F	2.70	3.80	2.30	3.20
218°C	425°F	2.93	4.10	2.50	3.46
232°C	450°F	3.16	4.41	2.69	3.72
246°C	475°F	3.39	4.71	2.89	3.98
260°C	500°F	3.62	5.01	3.08	4.42
274°C	525°F	3.86	5.31	3.28	4.51
288°C	550°F	4.11	5.62	3.49	4.79
302°C	575°F	4.35	5.93	3.69	5.06
316°C	600°F	4.60	6.24	3.90	5.33
330°C	625°F	4.86	6.55	4.10	5.60
343°C	650°F	5.11	6.87	4.31	5.88
357°C	675°F	5.37	7.18	4.52	6.16
371°C	700°F	5.63	7.50	4.73	6.44
385°C	725°F	5.90	7.82	4.94	6.73
399°C	750°F	6.16	8.15	5.16	7.02
413°C	775°F	6.43	8.47	5.38	7.31
427°C	800°F	6.70	8.80	5.60	7.60
441°C	825°F	6.97	9.13	5.82	7.89
454°C	850°F	7.25	9.46	6.05	8.19
469°C	875°F	7.53	9.79	6.27	8.48
482°C	900°F	7.81	10.12	6.49	8.78
496°C	925°F	8.08	10.46	6.71	9.07
510°C	950°F	8.35	10.80	6.94	9.37
524°C	975°F	8.62	11.14	7.17	9.66
538°C	1000°F	8.89	11.48	7.40	9.95
552°C	1025°F	9.17	11.82	7.62	10.24
566°C	1050°F	9.46	12.16	7.95	10.54
580°C	1075°F	9.75	12.50	8.18	10.83
593°C	1100°F	10.04	12.84	8.31	11.13
621°C	1150°F	10.57	13.52	8.76	11.71
649°C	1200°F	11.10	14.20	9.20	12.31
677°C	1250°F	11.66	14.88	9.65	12.88
704°C	1300°F	12.22	15.56	10.11	13.46
732°C	1350°F	12.78	16.24	10.56	14.05
760°C	1400°F	13.34	16.92	11.01	14.65

Movement is calculated as inches per 100 feet (30.5 m) between 75°F (24°C) and indicated temperature.

Conversion Factors (SI Units)

Quantity	SI Unit	Non-SI Unit	Conversions
Acceleration	$m.s^{-2}$	$ft.s^{-2}$	$1 m.s^{-2} = 3.281 ft.s^{-2}$ $1 ft.s^{-2} = 0.305 m.s^{-2}$
	$9.806 m.s^{-2}$	$32.174 ft.s^{-2}$	= Standard acceleration of gravity
Area	ha (hectare)	acre	$1 ha = 10,000 m^2 = 2.471 acres = 3.86 \times 10^{-3} mile^2$ $1 acre = 0.405 ha = 4046.86 m^2$
	m^2	ft^2	$1 m^2 = 10.764 ft^2$ $1 ft^2 = 9.290 \times 10^{-2} m^2$
	m^2	in^2	$1 m^2 = 1.550 \times 10^3 in^2$ $1 mm^2 = 1.550 \times 10^{-3} in^2$
	m^2	$mile^2$	$1 in^2 = 6.452 \times 10^{-4} m^2 = 645.2 mm^2$ $1 m^2 = 3.861 \times 10^{-7} mile^2$ $1 mile^2 = 2.589 \times 10^6 m^2 = 259 ha$
	m^2	yd^2	$1 m^2 = 1.196 yd^2$ $1 yd^2 = 0.836 m^2$
Density	$kg.m^{-3}$	$lb.ft^{-3}$	$1 kg.m^{-3} = 6.243 \times 10^{-2} lb.ft^{-3}$ $1 lb.ft^{-3} = 16.018 kg.m^{-3}$
	$kg.m^{-3}$	$lb.gal^{-1}$	$1 lb.gal^{-1} = 0.099 kg.dm^{-3}$
	$kg.m^{-3}$	$lb.in^{-3}$	$1 lb.in^{-3} = 27.679 g.cm^{-3}$
Energy (work)	J	Btu	$1 J = 9.478 \times 10^{-4} Btu$ $1 Btu = 1.055 \times 10^3 J$
	J	ft.lbf	$1 J = 0.738 ft.lbf$ $1 ft.lbf = 1.356 J$
	J	kcal	$1 J = 2.390 \times 10^{-4} kcal$ $1 kcal = 4.19 \times 10^3 J$
	J	kgf.m	$1 J = 0.102 kgf.m$ $1 kgf.m = 9.810 J$
	J	kWh	$1 J = 2.778 \times 10^{-7} kWh$ $1 kWh = 3.6 \times 10^6 J$
Force	N	kgf	$1 N = 0.102 kgf$ $1 kgf = 9.81 N = 2.205 lbf$
	N	lbf	$1 N = 0.225 lbf$ $1 lbf = 4.448 N$
	N	tonf	$1 N = 1.003 \times 10^{-4} tonf$ $1 tonf = 9964 N$
Length	m	ft	$1 m = 3.281 ft$ $1 ft = 0.305 m$
	m	in (1")	$1 m = 39.37 in$ $1 in = 0.025 m$
	m	mile	$1 m = 6.214 \times 10^{-4} mile$ $1 mile = 1.609 \times 10^3 m$
	m	milli-inch ("thou")	$1 "thou" = 25.4 \mu m$
	m	yd	$1 m = 1.094 yd$ $1 yd = 0.914 m$

Conversion Factors (SI Units)

Quantity	SI Unit	Non-SI Unit	Conversions
Mass	kg	cwt	1 kg = 1.968×10^{-2} cwt 1 cwt = 50.802 kg
	kg	oz	1 kg = 35.274 oz 1 oz = 28.349 g
	kg	pound (lb)	1 kg = 2.203 lb 1 lb = 0.454 kg
	kg	ton	1 kg = 9.842×10^{-4} ton 1 ton = 1.016×10^3 kg = 1.016 tonne 1 tonne (= 1 metric tonne) = 1000 kg
Moment of force (torque)	N.m	kgf.m	1 N.m = 0.102 kgf.m 1 kgf.m = 9.807 N.m
	N.m	ozf.in	1 N.m. = 141.612 ozf.in 1 ozf.in = 7061.55 μ N.m
	N.m	lbf.ft	1 N.m = 0.738 lbf.ft 1 lbf.ft = 1.356 N.m
	N.m	lbf.in	1 N.m = 8.85 lbf.in 1 lbf.in = 0.113 N.m
	N.m	tonf.ft	1 kN.m = 0.329 tonf.ft 1 tonf.ft = 3.037 kN.m
Moment of inertia	kg.m ²	oz.in ²	1 kg.m ² = 5.464×10^3 oz.in ² 1 oz.in ² = 1.829×10^{-5} kg.m ²
	kg.m ²	lb.ft ²	1 kg.m ² = 23.730 lb.ft ² 1 lb.ft ² = 0.042 kg.m ²
	kg.m ²	lb.in ²	1 kg.m ² = 3.417×10^3 lb.in ² 1 lb.in ² = 2.926×10^{-4} kg.m ²
Power	W	ft.lbf.s ⁻¹	1 W = 0.738 ft.lbf.s ⁻¹ 1 ft.lbf.s ⁻¹ = 1.356 W
	W	hp	1 W = 1.341×10^{-3} hp 1 hp = 7.457×10^2 W
	W	kgf.m.s ⁻¹	1 W = 0.102 kgf.m.s ⁻¹ 1 kgf.m.s ⁻¹ = 9.81 W
Pressure	Pa	bar	10^6 Pa = 1 MPa = 10 bar = 1 N.mm ⁻² 1 bar = 0.10 MPa = 14.504 psi
	Pa	ft H ₂ O (feet of water)	1 kPa = 0.335 ft H ₂ O 1 ft H ₂ O = 2.989 kPa
	Pa	in Hg (inch of mercury)	1 kPa = 0.295 in Hg 1 in Hg = 3.386 kPa
	Pa	kgf.m ⁻²	1 Pa = 0.102 kgf.m ⁻² 1 kgf.m ⁻² = 9.81 Pa
	Pa	kp.cm ⁻²	1 MPa = 10.194 kp.cm ⁻² 1 kp.cm ⁻² = 0.0981 MPa = 0.981 bar = 14.223 psi
	Pa	N.mm ⁻²	1 MPa = 1 N.mm ⁻² = 1 MN.m ⁻² = 10.197 kp.cm ⁻²
	Pa	lbf. ft ⁻²	1 kPa = 20.885 lbf. ft ⁻² 1 lbf. ft ⁻² = 47.880 Pa

Conversion Factors (SI Units)

Quantity	SI Unit	Non-SI Unit	Conversions
Pressure (continued)	Pa	psi (lbf.in ⁻²)	1 Pa = 1.450 x 10 ⁻⁴ lbf.in ⁻²
	Pa	ton.in ⁻²	1 lbf.in ⁻² = 6.895 kPa = 0.0703 kp.cm ⁻² = 0.0689 bar
	1.013x10 ⁵ Pa	14.696 lbf.in ⁻²	1 MPa = 6.477 x 10 ⁻² ton.in ⁻²
			1 ton.in ⁻² = 15.44 MPa = 15.44 N.mm ⁻² Standard atmosphere = 1.013 bar = 1.033 kp.cm ⁻²
Rate of flow (volumetric)	m ³ .s ⁻¹	ft ³ .s ⁻¹ (cusec)	1 m ³ .s ⁻¹ = 35.314 ft ³ .s ⁻¹
	m ³ .s ⁻¹	imperial gal.h ⁻¹	1 ft ³ .s ⁻¹ = 0.028 m ³ .s ⁻¹ = 28.317 dm ³ .s ⁻¹
	m ³ .s ⁻¹	in ³ .min ⁻¹	1 m ³ .s ⁻¹ = 7.919 x 10 ⁵ imp gal.h ⁻¹
	m ³ .s ⁻¹	US gal. min ⁻¹	1 imp gal.h ⁻¹ = 1.263 x 10 ⁻⁶ m ³ .s ⁻¹ = 4.546 dm ³ .h ⁻¹ 1 m ³ .s ⁻¹ = 3.661 x 10 ⁶ in ³ .min ⁻¹ 1 in ³ .min ⁻¹ = 2.731 x 10 ⁻⁷ m ³ .s ⁻¹ 1 m ³ .s ⁻¹ = 1.585 x 10 ⁴ US gal. min ⁻¹ 1 US gal. min ⁻¹ = 6.309 x 10 ⁻⁵ m ³ .s ⁻¹
Temperature	K	°C	K = °C + 273.15
		°F	°C = K - 273.15 °C = (°F - 32) x 0.556 °F = (°C x 1.8) + 32
Velocity	m.s ⁻¹	ft.s ⁻¹	1 m.s ⁻¹ = 3.281 ft.s ⁻¹
	m.s ⁻¹	km.h ⁻¹	1 ft.s ⁻¹ = 0.305 m.s ⁻¹ 1 m.s ⁻¹ = 3.6 km.h ⁻¹
	m.s ⁻¹	mile.h ⁻¹	1 km.h ⁻¹ = 0.278 m.s ⁻¹ 1 m.s ⁻¹ = 2.237 mile.h ⁻¹ 1 mile.h ⁻¹ = 0.447 m.s ⁻¹ = 1.467 ft.s ⁻¹
Viscosity (dynamic)	Pa.s	P (poise)	1 Pa.s = 10 P
	Pa.s	lbf.s.ft ⁻²	1 P = 0.1 Pa.s 1 Pa.s = 2.089 x 10 ⁻² lbf.s.ft ⁻² 1 lbf.s.ft ⁻² = 47.880 Pa.s
Viscosity (kinematic)	m ² .s ⁻¹	ft ² .s ⁻¹	1 m ² .s ⁻¹ = 10.764 ft ² .s ⁻¹
	m ² .s ⁻¹	in ² .s ⁻¹	1 ft ² .s ⁻¹ = 9.290 x 10 ⁻² m ² .s ⁻¹
	m ² .s ⁻¹	St (stokes)	1 in ² .s ⁻¹ = 6.452 cm ² .s ⁻¹ = 645.16 cSt 1 m ² .s ⁻¹ = 10 ⁴ St 1 St = 10 ⁻⁴ m ² .s ⁻¹
Volume (capacity)	m ³	ft ³	1 m ³ = 35.315 ft ³
	m ³	imperial fl oz	1 ft ³ = 0.028 m ³ 1 fl oz = 28.413 cm ³
	m ³	imperial gal	1 m ³ = 2.199 x 10 ² imp gal 1 imp gal = 4.546 x 10 ⁻³ m ³
	m ³	imperial pt (pint)	1 pt = 0.568 dm ³
	m ³	in ³	1 m ³ = 6.102 x 10 ⁴ in ³ 1 in ³ = 1.639 x 10 ⁻⁵ m ³
m ³	litre (L)	1 L = 10 ⁻³ m ³ = 0.220 imp gal = 0.264 US gal	
m ³	US gal	1 m ³ = 2.642 x 10 ² US gal 1 US gal = 3.785 x 10 ⁻³ m ³	

Glossary of Terms

Active Length (Flex Length): The portion of the flexible part of the joint that is free to move.

Ambient Temperature: The external environment temperature adjacent to the external face of the expansion joint.

Anchor: Terminal point or fixed point from which directional movement occurs.

Angles: L-shaped steel member used either as a duct flange or as the fastening member of an expansion joint used for bolting or welding the joint to the mating flange surfaces of the ductwork or adjacent equipment.

Angular Movement: The movement which occurs when one flange of the expansion joint is moved to an out of parallel position with the other flange. Such movement is measured in degrees.

Angular Deflection: See *Angular Movement*.

Angular Offset: See *Angular Movement*.

Assembled Splice: A splice that is constructed of multi-layers of materials and connected by mechanical means such as adhesives, stitching, or lacing hooks.

Axial Compression: The dimensional shortening of an expansion joint parallel to its longitudinal axis. Such movement is measured in inches or millimeters and usually caused by thermal expansion of the ducting system.

Axial Elongation: See *Axial Extension*.

Axial Extension: The dimensional lengthening of an expansion joint parallel to its longitudinal axis. Such movement is measured in inches or millimeters.

Backing Bars: See *Back-Up Bars*.

Back-Up Bars: Metal bars used for the purpose of clamping the expansion joint to mating ductwork flanges or clamping the fabric portion of a belted type of joint to the metal adapter flanges.

Baffle (Flow Liner): A shield that is designed to protect the expansion joint from the abrasive particles in the gas stream and/or to reduce the flutter caused by the air turbulence in the gas stream and in some cases may be part of the overall thermal protection system.

Bearing Point: See *Fixed Point*.

Belt: The flexible element of an expansion joint.

Belt Type Expansion Joint: An expansion joint in which the flexible element of the joint is made like a flat belt and is bolted or clamped to metal adapter flanges or frame.

Bolster: Also known as a cavity pillow. The cavity pillow fills the cavity between the flexible element and the flow liner or baffle and helps minimize the accumulation of particulate matter, and in some applications unburned fuel, from becoming trapped in the expansion joint cavity.

Bolt Hole Pattern or Drill Pattern: The systematic location of bolt holes in the duct flanges and expansion joint flanges where the joint is to be bolted to ducting flanges.

Bolt-in Baffle (Flow liner): A baffle that is designed to be bolted to the breach flange. This design can be either single or double acting and requires the use of a seal gasket.

Bolt Torque: The torque with which bolts must be fastened. This varies according to bolt dimensions, bolt lubrication, flange pressure etc.

Boot or Belt: The flexible element of an expansion joint.

Breach Flange or Duct Flange: The portion of the duct system, usually an angle or a channel that interfaces with the flange of the expansion joint.

Breach Opening or Duct Face-to-Face Distance: The distance between the mating duct flanges in which the joint is to be installed.

Cavity Pillow: The cavity pillow fills the cavity between the flexible element and the baffle (flow liner) and helps minimize the accumulation of particulate matter, and in some applications unburned fuel, from becoming trapped in the expansion joint cavity.

Chimney Joint: A special type of seal or expansion joint used in chimneys or flues.

Clamp Bars: See *Back-Up Bars*.

Clamping Area: That part of the expansion joint which is covered by the back-up bar.

Cold Pre-Set: See *Pre-set*.

Combination Type Expansion Joint: An expansion joint which utilizes both belt type and flanged expansion joint clamping configurations.

Compensator: See *Expansion Joint*.

Composite Type Expansion Joint: An expansion joint in which the various plies are of different materials that are not integrally bonded together. It is normally made up of an inside liner, thermal insulating barrier and an outer cover. Other special plies can be included.

Concurrent Movements: Combination of two or more types (axial or lateral) of movements.

Continuous Temperature Rating: Temperature at which an expansion joint may be operated continuously with safety.

Corners: Molded, formed, or radiused belt corners of rectangular expansion joint.

Cuff: The flange reinforcement that is an additional sheath of fabric to protect the expansion joint from thermal and/or mechanical degradation.

Design Temperature: The maximum or most severe temperature expected during normal operation, not including periods of abnormal operation caused by equipment failure. (See excursion temperature).

Design Pressure/Vacuum: The maximum or most severe pressure/vacuum expected during normal operation, not including periods of abnormal operation caused by equipment failure. During cyclic phases in the system, both pressure and vacuum conditions may occur.

Dew Point: The temperature at which gasses condense to form a liquid. Acid dew point varies with gas composition and is a higher temperature than the moisture dew point.

Double-Acting Flow Liner: A shield constructed so that the liner is formed of two pieces, each providing protection against fly ash or media flow. One piece is attached to each side of the frame or ductwork, joined by the expansion joint (see also Internal flow liner).

Glossary of Terms

Drain: A fitting to drain the expansion joint of condensate or other liquids that collect at the lowest point.

Drill Pattern: The systematic location of bolt holes on the breach flange to which the expansion joint will be attached.

Duct Flange: See *Breach Flange*.

Duct Face-To-Face Distance: see *Breach Opening*.

Duct I.D.: The inside dimension of the ductwork measured from the duct walls.

Effective Length: See *Active Length*.

Elastomer: Designation for rubber and synthetic polymers.

Excursion Temperature: The temperature the system could reach during an equipment failure, such as an air heater failure. Excursion temperature should be defined by maximum temperatures and time duration of excursion.

Expansion Joint: Non-metallic expansion joints are flexible connectors designed to provide stress relief and seal in gaseous media in ducting systems. They are fabricated from a wide variety of non-metallic materials, including synthetic elastomers, fabrics, insulation materials and fluoroplastics, depending on the designs.

Expansion Joint Assembly: The complete expansion joint, including, where applicable, the flexible element, the frame and any flow liners or ancillary components.

Expansion Joint Frame: A metal frame on which the expansion joint is attached. The frame may incorporate flow liners.

External Arch Corner: An expansion joint corner with the arch formed outwardly that is designed primarily for pressure service, generally used in conjunction with a molded joint.

External Influences: Forces or environment acting on the expansion joint assembly from outside of the process.

External Insulation: Insulation materials applied to the outside of either the duct or expansion joint.

Fabric Expansion Joint: See *Expansion Joint*.

Fabric Flanged Type Expansion Joint: See *Flanged Expansion Joint*.

Fastening Elements: Bolts, nuts, studs, washers and other items for securing a connection.

Fatigue: Condition which sets in when joint components have been subjected to stress. It is depends on the severity and frequency of operating cycles.

Field Assembly: A joint that is assembled at the jobsite.

Finite Element Analysis (FEA): Study of a structure and its components to ensure that the design meets the required performance criteria for thermal, vibration, shock and structural integrity.

Fixed Point: The point at which the ducting system is anchored.

Fixings: The mechanical system for holding the expansion joint in position and creating a seal between the joint and the duct system.

Flanged Expansion Joint: An expansion joint when installed takes the "U" shaped configuration.

Flange Gasket: A gasket which is inserted between two adjacent flanges to form a gas-tight connection.

Flange Reinforcement: See *Cuff*.

Flexible Element: See *Expansion Joint*.

Flexible Length: See *Active Length*.

Fly Ash Seal: A flexible element that is attached between the baffle plates and/or duct wall to restrict the buildup of fly ash between the baffle and joint body. This element is not gas tight.

Frame: The complete angle iron or plate frame to which flexible element portion of the expansion joint is attached.

Free Length: See *Active Length*.

Gas Flow Velocity: See *Flow Velocity*.

Gas Seal: The specific ply in the flexible element that is designed to stop gas penetration.

Inner Ply: The gas side ply of the flexible element.

Installed Face-to-Face Distance: The distance between the expansion joint frames after installation when the system is in the cold position.

Insulation: Materials used to protect the outer cover in composite constructions from thermal degradation. Also used in cavity pillows. (See *also Cavity Pillow*).

Internal Arch Corner: An expansion joint corner with the arch formed inwardly (concave), designed primarily for vacuum service. Used generally in conjunction with a molded joint.

Joint Cuff: See *Cuff*.

Lateral Movement: The relating displacement of the two ends of the expansion joint perpendicular to its longitudinal axis.

Lateral Offset: The offset distance between two adjacent duct flanges or faces.

Leakage Rate: The rate of leaking through the flexible elements bolt holes and mounting interface areas.

Life Cycles: The cumulative number of times the flexible element moves from the cold to hot position and then back to cold again until failure.

Lifting Lugs: A lifting device that is attached to the metal portion of the expansion joint frame for field handling and erection.

Limiting Stress: The load which, when applied, does not exceed the elastic limits of the material and provides a safe operating level.

Manufactured Face-to-Face of Expansion Joint: The manufactured width of the flexible element measured from joint flange face to flange face.

Maximum Design Temperature: The maximum temperature that the system may reach during normal operating conditions. This is not to be confused with excursion temperature.

Membrane: A ply of material.

Glossary of Terms

Misalignment: The out-of-line condition that exists between the adjacent faces of the breach or duct flanges during ductwork assembly.

Molded Type Expansion Joint: An expansion joint in which the entire wall of the joint is molded into a "U" or a convoluted configuration. The joint is manufactured by a molding process.

Movements: The dimensional changes which the expansion joint assembly is required to absorb, such as those resulting from thermal expansion or contraction.

Multi-Layer Expansion Joint (Composite): An expansion joint in which the various plies are of different materials which are not integrally bonded together.

Needle-Mat: See *Insulation*.

Noise Attenuation: The reduction of noise transmitted through the expansion joint systems construction.

Nominal Thickness: The nominal thickness is not to be less than 85% of the stated normal value.

Non-Metallic Expansion Joint: See *Expansion Joint*.

Operating Pressure/Vacuum: The pressure or vacuum condition which occurs during normal performance.

Operating Temperature: The gas temperature at which the system generally will operate during normal conditions.

Outer Cover: The external side of the flexible element.

Pantograph Control Mechanism: See *Scissors Control Guide*.

Pre-Assembled Joint: The combination of the metal framework and a flexible element, factory assembled into a single assembly.

Pre-Compression: Compressing the flexible element (shortening the installed F/F).

Pre-Set: Dimension that flexible elements are deflected to ensure that desired movements will take place. See *Lateral Offset* and *Manufactured F/F*.

Primary Seal: The component designed as the main means of preventing leakage through the expansion joint (See also *Secondary Seal*).

Protective Shipping Cover: Material used to protect the flexible element during shipment and installation.

Protective Strip or Rub Tape: Fabric material or tadpole tape sometimes used between flexible element and metal member of expansion joint assembly to protect flexible element from heat transfer or abrasion.

Pulsation: See *Flutter*.

Resultant Movement: The net effect of concurrent movements.

Scissors Control Guide: A special metal construction using a "scissors" principle that is used to distribute large movements uniformly between two or more flexible elements in line and combined.

Secondary Seal: The component designed as a back up to the primary seal for preventing leakage through the flexible element (See also *Primary Seal*).

Service Life: Estimated time the expansion joint will operate without the need of replacement.

Set Back (Stand Off Height): The distance the expansion joint is set back from gas stream to allow for lateral movements and to prevent the joint from protruding into the gas stream or rubbing on the baffle when operating under negative pressure.

Shipping Straps or Bars: Braces that are located between the two expansion joint flanges to prevent over-compression or distortion during shipment and joint assembly.

Simultaneous Movements: See *Concurrent Movements*.

Single-Layer Expansion Joint: Expansion joint formed of one consolidated layer, often constructed from elastomers and reinforcement materials or fluoroplastics and reinforcement materials.

Site Assembly: A joint which is assembled at the job site.

Sleeve Type Expansion Joint: See *Belt Type Expansion Joint*.

Splices: Procedure for making endless flexible elements from open ended material. Splicing may be accomplished by one or more of the following; cementing, heat sealing, stitching, vulcanizing or mechanical fasteners.

Splicing Kit: A collection of all materials and appropriate specialist tools required to join or splice a flexible element during site assembly.

Splicing Material: Material used for affecting a splice in a flexible element.

Spring Rate: The force (lb/in) required to move the flexible element in compression, extension and laterally.

Stand Off Height: See *Set Back*.

Support Layer: Keeps the insulation in place and provides protection during handling and operation.

Telescopic Flow Liner: See *Double-Acting Flow Liner*.

Tensile Strength: Ability of a material to resist or accommodate loads until the breakage point.

Thermal Barrier: A layer of insulating material designed to reduce the surface temperature at the gas sealing layer to a level compatible with its heat resistance capability.

Thermal Movements: Movements created within the duct system by thermal expansion. Can be axial, lateral or torsional.

Torsional Movement: The twisting of one end of an expansion joint with respect to the other end along its longitudinal axis. Such movement being measured in degrees same as angular movement.

Transit Bars: See *Shipping Straps*.

Vulcanized Splice: A splice of elastomeric materials that are bonded with heat and pressure.

Wear Resistance: The ability of a material to withstand abrasive particles without decomposition.

Welding Blanket: A fire resistant blanket that is placed over the expansion joint to protect it from weld splatter during field welding operations.

Weld In Baffle: A flow liner designed to be welded to the duct wall or expansion joint frame. This design can be either single or double acting type.

Flexi-Duct™ Expansion Joint Data Specification Sheet

Customer	Customer's Name:		Date:		Page:		
	Address:		Project Name:		Delivery Req'd By:		
	City, State/Prov., Postal Code:		Specification #		Inquiry #		
	Name of Person Submitting Data:	Tel: Fax:	Item# / Tag #	Item# / Tag #	Item# / Tag #		
	Quantity Per Item:						
	New or Replacement:						
Service	Type of Plant/Service (Precipitator, Scrubber, etc) :						
	Type of Fuel & Percent Sulfur:						
	Peak Load or Base Load:						
	Number of Startups & Shutdowns Per Year:						
	Location of Expansion Joint (Inside Diameter Fan Outlet, Stack, etc) :						
Size	Duct Size (Inside Dimensions or Diameter) :		FT	IN	FT	IN	
	Face-to-Face Dimension (If Replacement Required) :			IN		IN	
Gas	Flowing Medium (Air, Flue, Gas, etc) :						
	Dust Load:			PSF		PSF	
	Flow Velocity:			FPS		FPS	
	Flow Direction (Up, Down, Horizontal, Angular Up, Angular Down, etc) :						
Press	Design Pressure	Maximum		IN H ₂ O		IN H ₂ O	
		Normal		IN H ₂ O		IN H ₂ O	
Temperature	Gas Temperature	Normal Continuous			°F		
		Maximum (Upset)	Temperature			°F	
			Duration Per Event			HR	
			Cumulative Duration			HR	
	Ambient Temperature	Maximum			°F		
Minimum			°F				
Movement	Axial Compression:			IN		IN	
	Axial Extension:			IN		IN	
	Lateral:			IN		IN	
	Angular:			°		°	
	Torsional:			°		°	
Duct	Duct Material:						
	Duct Thickness:			IN		IN	
	Duct Corner (Radius or Square):						
	Baffle (Flow Liner)						

THORBURN FLEX - Canada
 165 Oneida, Pointe-Claire, Quebec
 Canada, H9R 1A9
 Tel: +1-514-695-8710
 Fax: +1-514-695-1321
 sales@thorburnflex.com



ISCIR Romania | CNCAN Romania | EN 13480-2002 | HAF 604 China | TSG China
 (CRN for all Canadian Provinces)

Thorburn's Global Presence

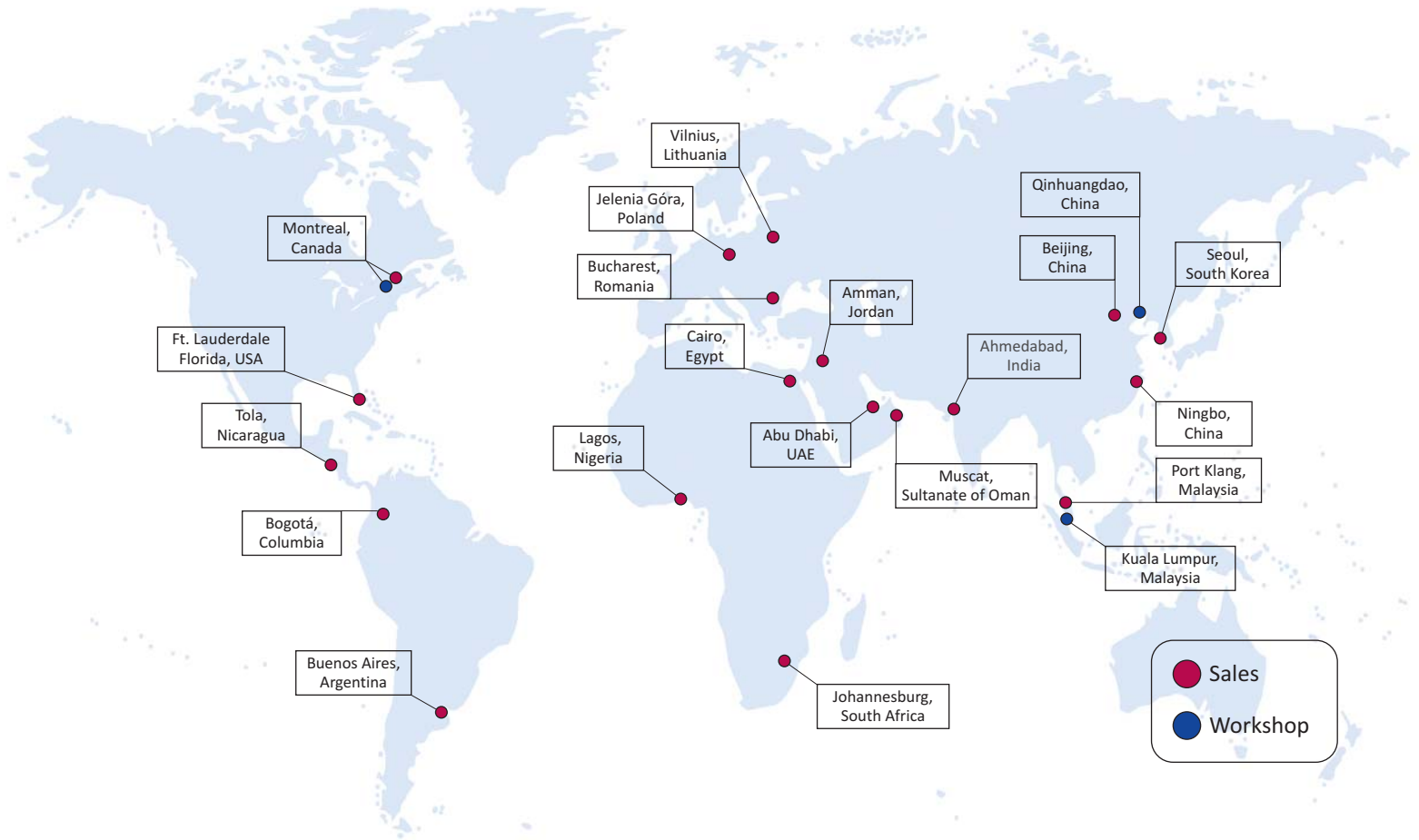

www.thorburnflex.com